

HSK-ER弹簧夹头刀柄 HSK-ER Spring Chuck

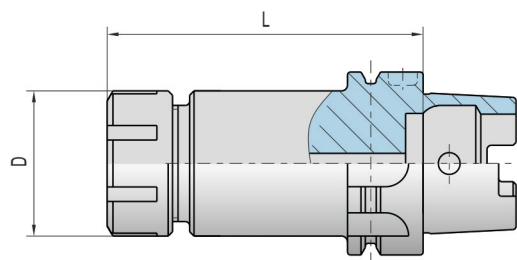

型号 Type	库存 Stock Item	尺寸(mm) Dimension		夹持范围 Clamping range	卡簧 Collets	锁紧螺母 Screw	扳手 Wrench	重量 (kg) Weight
		D	L					
HSK40A-ER20-80	○	34	80	0.5-13	ER20	CN20	BCN20UM	0.55
HSK50A-ER20-80	○	34	80	0.5-13	ER20	CN20	BCN20UM	0.7
-ER25-75	○	42	75	0.5-16	ER25	CN25	BCN25	1
-ER32-100	○	50	100	1-20	ER32	CN32	BCN32	1.45
HSK63A-ER16-75	○	28	75	0.5-10	ER16	CN16	BCN16UM	1
-ER16-100	○	28	100	0.5-10	ER16	CN16	BCN16UM	1.1
-ER16-120	○	28	120	0.5-10	ER16	CN16	BCN16UM	1.2
-ER20-80	○	34	80	0.5-13	ER20	CN20	BCN20UM	1
-ER20-100	○	34	100	0.5-13	ER20	CN20	BCN20UM	1.1
-ER20-120	○	34	120	0.5-13	ER20	CN20	BCN20UM	1.2
-ER25-80	○	42	80	0.5-16	ER25	CN25	BCN25	1.1
-ER25-100	○	42	100	0.5-16	ER25	CN25	BCN25	1.4
-ER25-120	○	42	160	0.5-16	ER25	CN25	BCN25	1.8
-ER32-80	○	50	80	1-20	ER32	CN32	BCN32	1.4
-ER32-100	○	50	100	1-20	ER32	CN32	BCN32	1.6
-ER32-120	○	50	160	1-20	ER32	CN32	BCN32	2
-ER40-100	○	63	80	2-26	ER40	CN40	NCN40	2.4
-ER40-120	○	63	100	2-26	ER40	CN40	NCN40	2.6
HSK100A-ER20-100	○	34	100	0.5-13	ER20	CN20	BCN20UM	3.5
-ER20-160	○	34	160	0.5-13	ER20	CN20	BCN20UM	3.9
-ER25-100	○	42	100	0.5-16	ER25	CN25	BCN25	3.8
-ER25-160	○	42	160	0.5-16	ER25	CN25	BCN25	4.2
-ER32-100	○	50	100	1-20	ER32	CN32	BCN32	4
-ER32-160	○	50	160	1-20	ER32	CN32	BCN32	4.7
-ER40-100	○	63	100	2-26	ER40	CN40	NCN40	4.5
-ER40-160	○	63	160	2-26	ER40	CN40	NCN40	5

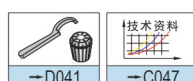

●库存 stock item
○准库存 under preparing for stock



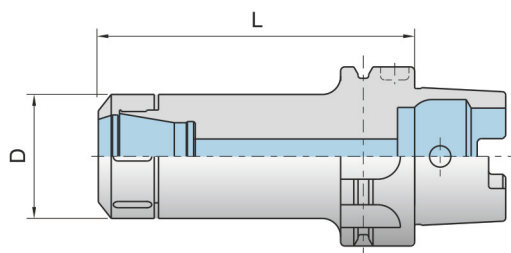

高精度铣刀夹头刀柄 High precision milling chuck holder



型号 Type	库存 Stock Item	尺寸(mm) Dimension		卡簧 Collets 	锁紧螺母 Screw 	扳手 Wrench 	夹持范围 Clamping range
		D	L				
HSK63A-LT06-100	○	20	100	LT06	LTER06	LTB06	2-6
LT06-125	○	20	125				
LT06-150	○	20	150				
LT10-100	○	35	100	LT10	LTER10	LTB10	2-10.3
LT10-125	○	35	125				
LT10-150	○	35	150				
LT10-200	○	35	200				
LT16-100	○	46	100	LT16	LTER16	LTB16	4-16
LT16-125	○	46	125				
LT16-150	○	46	150				
LT16-200	○	46	200	LT25	LTER25	LTB25	8-25
LT25-105	○	58	105				
LT25-125	○	58	125				
LT25-150	○	58	150				
LT25-200	○	58	200				

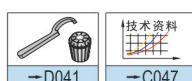

D

●库存 stock item
○准库存 under preparing for stock

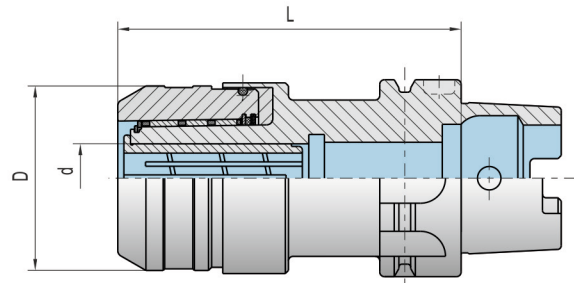

HSK强力铣刀柄 HSK Strong Milling Holder



型号 Type	库存 Stock Item	尺寸(mm) Dimension			卡簧 Collets 	扳手 Wrench 	重量 (kg) Weight 
		D	d	L			
HSK63A-C20-110	○	52	16	110	C16	WC16	1.50
-C32-110	○	68	32	111	C32	WC32	2.20
HSK100A-C32-105	○	68	32	105	C32	WC32	4.60
-C42-115	○	87	42	115	C42	WC42	5.50

- 库存 stock item
- 准库存 under preparing for stock



HSK烧结式热装刀柄 HSK sintered Sink-Fit Holder

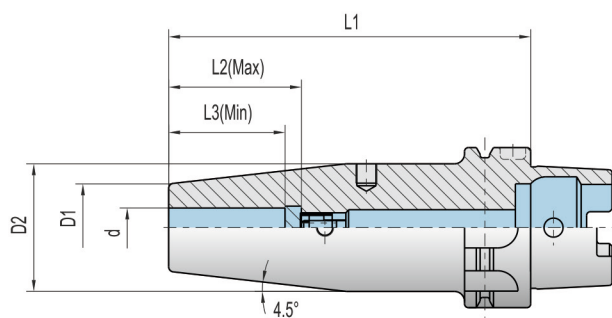

型号 Type	库存 Stock Item	尺寸(mm) Dimension						重量 (kg) Weight kg
		d	D1	D2	L1	L2(Max)	L3(Min)	
HSK63A-SF3-80	○	3	10	10	80	-	9	0.50
-SF4-80	○	4	10	10	80	-	12	0.60
-SF5-80	○	5	10	10	80	-	15	0.70
-SF6-80	○	6	21	27	80	28	18	0.80
-SF6-130	○	6	21	27	130	28	18	1.00
-SF6-160	○	6	21	27	160	28	18	1.20
-SF8-80	○	8	21	27	80	34	24	0.80
-SF8-130	○	8	21	27	130	34	24	1.02
-SF8-160	○	8	21	27	160	34	24	1.25
-SF10-85	○	10	24	32	85	40	30	0.90
-SF10-130	○	10	24	32	130	40	30	1.17
-SF10-160	○	10	24	32	160	40	30	1.45
-SF12-90	○	12	24	32	90	40	30	0.92
-SF12-130	○	12	24	32	130	40	30	1.15
-SF12-160	○	12	24	32	160	40	30	1.55
-SF16-95	○	16	27	34	95	42	32	1.00
-SF16-130	○	16	27	34	130	42	32	1.21
-SF16-160	○	16	27	34	160	42	32	1.65

● 库存 stock item
○ 准库存 under preparing for stock

D



HSK烧结式热装刀柄 HSK sintered Sink-Fit Holder

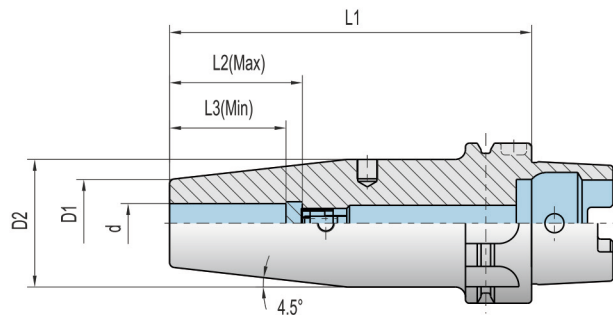

型号 Type	库存 Stock Item	尺寸(mm) Dimension						重量 (kg) Weight kg
		d	D1	D2	L1	L2(Max)	L3(Min)	
HSK100A-SF6-85	○	6	21	27	85	28	18	2.00
-SF6-130	○	6	21	27	130	28	18	2.30
-SF6-160	○	6	21	27	160	28	18	2.62
-SF8-85	○	8	21	27	85	34	24	2.00
-SF8-130	○	8	21	27	130	34	24	2.30
-SF8-160	○	8	21	27	160	34	24	2.65
-SF10-90	○	10	24	32	90	40	30	2.20
-SF10-130	○	10	24	32	130	40	30	2.40
-SF10-160	○	10	24	32	160	40	30	2.70
-SF12-95	○	12	24	32	95	40	30	2.30
-SF12-130	○	12	24	32	130	40	30	2.50
-SF12-160	○	12	24	32	160	40	30	2.75
-SF16-100	○	16	27	34	100	42	32	2.50
-SF16-130	○	16	27	34	130	42	32	2.80
-SF16-160	○	16	27	34	160	42	32	3.13
-SF20-105	○	20	33	42	105	50	40	2.60
-SF20-130	○	20	33	42	130	50	40	2.90
-SF20-160	○	20	33	42	160	50	40	3.25
-SF25-115	○	25	44	53	115	55	45	2.80
-SF25-160	○	25	44	53	160	55	45	3.40
-SF32-120	○	30	44	53	120	60	50	3.20
-SF32-160	○	32	44	53	160	60	50	3.60

- 库存 stock item
- 准库存 under preparing for stock





HSK侧固式刀柄 HSK Side Fixing Holder

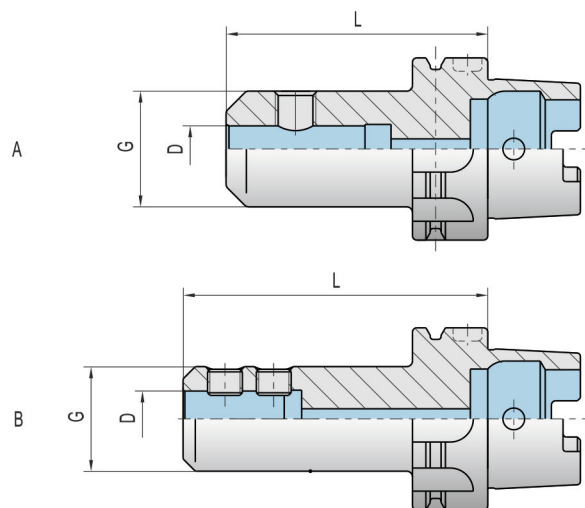

型号 Type	库存 Stock Item	尺寸(mm) Dimension			安装形式 Model	螺钉 Screw	扳手 Wrench	重量 (kg) Weight kg
		D	d1	L				
HSK63A-SLA16-100	○	16	48	100	A	PM1416	S6	1.70
-SLA20-100	○	20	52	100	A	PM1616	S8	1.80
-SLA25-100	○	25	65	100	B	PM1814	S8	2.50
-SLA32-110	○	32	72	110	B	PM2018	S10	2.70
HSK100A-SLA16-100	○	16	48	100	A	PM1416	S6	3.80
-SLA20-100	○	20	52	100	A	PM1616	S8	3.90
-SLA25-100	○	25	65	100	B	PM1814	S8	4.00
-SLA32-100	○	30	72	100	B	PM2018	S10	4.10

●库存 stock item

○准库存 under preparing for stock

D



HSK自紧式钻夹头刀柄 HSK Self-tightening Drill Chuck

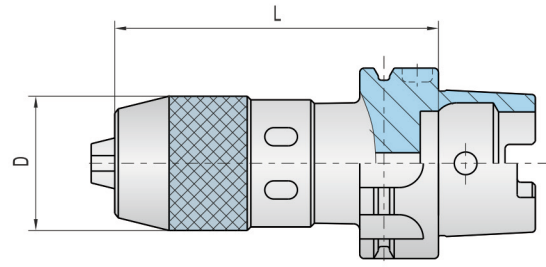

型号 Type	库存 Stock Item	尺寸(mm) Dimension		夹持范围 Clamping range	重量 (kg) Weight kg
		D	L		
HSK40A-APU08-120	○	36.3	120	1-8	0.80
HSK50A-APU08-120	○	63.3	120	1-8	1.61
HSK63A-APU08-120	○	36.3	120	1-8	2.45
-APU13-150	○	51.5	150	1-13	2.65
-APU16-155	○	58	155	3-16	3.12
HSK100A-APU13-155	○	51.5	155	1-13	4.23
-APU16-160	○	58	160	3-16	4.55

- 库存 stock item
- 准库存 under preparing for stock





HSK面铣刀刀柄 HSK Face Milling Holder

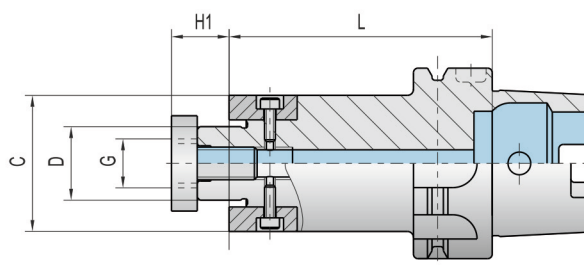

型号 Type	库存 Stock Item	尺寸(mm) Dimension				重量 (kg) Weight
		D	L	C	H1	
HSK50A-FMB16-50	○	16	50	38	17	0.80
-FMB22-60	○	22	60	48	19	1.00
-FMB27-60	○	27	60	58	21	1.10
-FMB32-60	○	32	60	78	24	1.30
HSK63A-FMB16-50	○	16	50	38	17	1.30
-FMB16-100	○	16	100	38	17	1.80
-FMB22-50	○	22	50	48	19	1.30
-FMB22-100	○	22	100	48	19	1.80
-FMB27-60	○	27	60	58	21	1.60
-FMB27-100	○	27	100	58	21	2.30
-FMB32-60	○	32	60	78	24	2.00
-FMB32-100	○	32	100	78	24	2.80
-FMB40-60	○	40	60	88	25	2.20
-FMB40-100	○	40	100	88	25	3.00
HSK100A-FMB22-50	○	22	50	48	19	2.90
-FMB27-50	○	27	50	68	21	2.90
-FMB32-50	○	32	50	78	24	3.80
-FMB40-60	○	40	60	88	25	4.10
-FMC40-50	○	40	50	88	27	4.40
-FMB60-70	○	60	70	129	25	5.50

●库存 stock item

○准库存 under preparing for stock

D

HSK有扁尾莫氏锥孔刀柄 HSK with Flat Morse Taper Holder

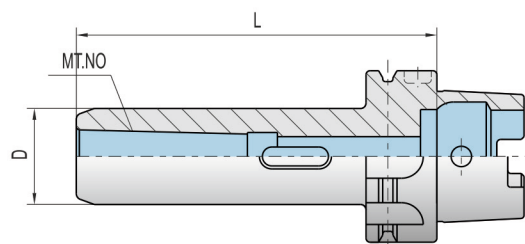

型号 Type	库存 Stock Item	尺寸(mm) Dimension		莫氏圆锥号 MTA.NO.	重量 (kg) Weight
		D	L		
HSK50A-MTA1-100	○	25	100	1	1.50
-MTA2-120	○	32	120	2	1.80
-MTA3-140	○	40	140	3	1.90
HSK63A-MTA1-100	○	25	100	1	1.90
-MTA2-120	○	32	120	2	2.00
-MTA3-140	○	40	140	3	2.20
-MTA4-160	○	40	160	4	2.50
HSK100A-MTA1-110	○	25	110	1	3.40
-MTA2-120	○	32	120	2	3.90
-MTA3-150	○	40	150	3	4.00
-MTA4-170	○	48	170	4	4.60
-MTA5-200	○	63	200	5	5.20

●库存 stock item
○准库存 under preparing for stock

