

- DIN5480
- DIN5482
- BARUFFALDI
- DIN1809

4

4

*Choose the right model
to have the best machining!*

VDI DRIVEN TOOLS

Portautensili motorizzati / Driven Tools

DIN5480 DRIVEN TOOLS

ASSIALE PORTA PINZA AXIAL COLLET CHUCK	RADIALE PORTA WELDON RADIAL WELDON CHUCK	ORIENTABILE ±90° ADJUSTABLE ±90°
ASSIALE PORTA FRESA AXIAL SHELL END MILLING CUTTER	ARRETRATO PORTA PINZA REAR OFFSET COLLET CHUCK	
ASSIALE PORTA WELDON AXIAL WELDON CHUCK	DOPPIO RADIALE PORTA PINZA DOUBLE RADIAL COLLET CHUCK	
RADIALE PORTA PINZA RADIAL COLLET CHUCK	DISASSATO PORTAPINZA OFFSET AXIS COLLET CHUCK	
RADIALE PORTA FRESA RADIAL SHELL END MILLING CUTTER	DISASSATO PORTA FRESA OFFSET AXIS SHELL END MILLING CUTTER	

BARUFFALDI DRIVEN TOOLS

ASSIALE PORTA PINZA AXIAL COLLET CHUCK	RADIALE DOPPIO PORTA PINZA DOUBLE RADIAL COLLET CHUCK
ASSIALE PORTA FRESA AXIAL SHELL END MILLING CUTTER	ORIENTABILE ±90° ADJUSTABLE ±90°
RADIALE PORTA PINZA RADIAL COLLET CHUCK	
RADIALE PORTA FRESA RADIAL SHELL END MILLING CUTTER	
ARRETRATO PORTA PINZA REAR OFFSET COLLET CHUCK	
ARRETRATO PORTA FRESA REAR OFFSET SHELL END MILLING CUTTER	

PAGE 4.21 - 4.28

DIN5482 DRIVEN TOOLS

ASSIALE PORTA PINZA AXIAL COLLET CHUCK	ARRETRATO PORTA FRESA REAR OFFSET SHELL END MILLING CUTTER
ASSIALE PORTA FRESA AXIAL SHELL END MILLING CUTTER	ORIENTABILE ±90° ADJUSTABLE ±90°
RADIALE PORTA PINZA RADIAL COLLET CHUCK	
RADIALE PORTA FRESA RADIAL SHELL END MILLING CUTTER	
ARRETRATO PORTA PINZA REAR OFFSET COLLET CHUCK	

PAGE 4.39 - 4.43

DIN1809 DRIVEN TOOLS

ASSIALE PORTA PINZA AXIAL COLLET CHUCK
RADIALE PORTA PINZA RADIAL COLLET CHUCK
ARRETRATO PORTA PINZA REAR OFFSET COLLET CHUCK
ORIENTABILE ±90° ADJUSTABLE ±90°

PIÙ SEMPLICE / PIÙ INFO / PIÙ PRODOTTI - EASIER / MORE INFO / MORE PRODUCTS

TROVA IL TUO PRODOTTO IN POCHI CLICK - FIND YOUR PRODUCT IN FEW CLICKS



by category



by code



by description



by configurator

Un nuovo modo facile e veloce per ordinare la tua attrezzatura Gerardi

Il nuovo Gerardi estore offre la possibilità di visualizzare e ordinare qualsiasi articolo Gerardi appartenente alle categorie Workholding o Tooling presente sui nostri listini in modo semplice, veloce e completo. Da ora puoi ordinare la morsa, la testa angolare o il motorizzato che ti interessa direttamente on-line dal nostro estore senza costi aggiuntivi.

A new quick and easy way to order your equipment branded Gerardi.

The new Gerardi estore offers the ability to view and order any item available on our Workholding and Tooling catalogues with the easiest, fastest and comprehensive way. You can now order the vise, angle head or driven tool of your interest directly online from our store without any additional cost.



WINDOWS / IOS



ANDROID / IPHONE



SIMBOLI TIPOLOGIE MOTORIZZATI DRIVEN TOOLS DESIGN LOGOS

Assiale Axial	Assiale doppio Double Axial	Disassato Offset Axis	Disassato Doppio Double Offset Axis	Radiale Radial	Radiale Doppio Double Radial	Radiale 4 Uscite Radial 4 Outputs	Radiale 8 Uscite Radial 8 Outputs
Radiale Rovesciato Radial Upside Down	Arretrato Rear Offset	Arretrato Doppio Double Rear Offset	Orientabile ±90° Adjustable ±90°	Portacreatore Driven Gear Hobber			

SIMBOLOGIA DATI TECNICI TECHNICAL DATA LOGOS

USCITA OUTPUT						
	Uscita HSK HSK output	Uscita ISO ISO output	Uscita portafresa Shell mill holder output	Uscita WELDON WELDON output	Uscita CAPTO CAPTO output	Portacreatore Driven Gear Hobber
PASSAGGIO REFRIGERANTE COOLANT						
				Refrigerante Esterno External Coolant	Refrigerante Interno Internal Coolant	Refrigerante Interno Internal Coolant
					20/25/80 100bar	ReCool NUT
USCITA OUTPUT						
			Rapporto Ratio	Rotazione uguale al mandrino Rotation same as machine spindle	Rotazione opposta al mandrino Rotation opposite as machine spindle	Rotaz. uguale ed opposta al mandrino Rotation same & opposite as machine spindle

Portautensili Motorizzati / Driven Tools

VDI



Velocità / High-speed
Max 24.000 Rpm



Internal coolant
fino a / Up to
100 Bar

Portautensili Motorizzati per torni CNC

Driven Tools for CNC lathes

USCITE MULTIPLE

MULTIPLE OUTPUTS

Tutti i motorizzati, ad esclusione di quelli ad angolo variabile, possono essere forniti con doppia pinza contrapposta anche di pari grandezza. Sono stati realizzati per i modelli di tornio più recenti anche motorizzati assiali con doppia / tripla uscita frontale e radiali doppia uscita frontale.

All the driven tools, with the exception of those with adjustable angle, can be supplied with double or multiple output even of the same dimension. Multiple outputs can be opposite or with the same direction.

ALTA VELOCITÀ RATIO 1:4

HIGH SPEED RATIO 1:4

(Opzione di moltiplica del numero di giri dalla torretta del tornio da 2 a 4 volte). Su richiesta, quasi tutti i modelli di motorizzati sono fornibili con velocità di rotazione fino a 24.000 Rpm. Questa soluzione permette di adeguare il numero di giri della torretta alle velocità di taglio delle nuove tipologie di utensili in commercio. Il sistema epicicloidale (interno) consente di mantenere inalterate le dimensioni di ingombro dei vari modelli, senza quindi penalizzare in alcun modo la funzionalità della macchina.

N.B: I MOTORIZZATI STANDARD CON RAPPORTO 1:1 HANNO REGIME DI ROTAZIONE MAX. 6.000 RPM.

All the driven tools types are available with speed until 24.000 Rpm. There is also the possibility of speed increaser from 2 to 4 times thus adapting the Rpm of the turret drive to the speed of today's cutting tools. The epicyclic speed increaser system (a system of satellite gears) is self contained in the standard head overall dimensions and guarantees the same standards of quality and reliability.

ATTENTION: THE STANDARD ROTARY TOOLS WITH 1:1 RATIO HAVE A MAX SPEED OF 6.000 Rpm

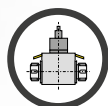

Radiale Doppio
Double Radial



Trattamento Corpo

Main body Treated

Treatmento protettivo anti-ossidante del corpo

Specially treated corrosion resistant steel body

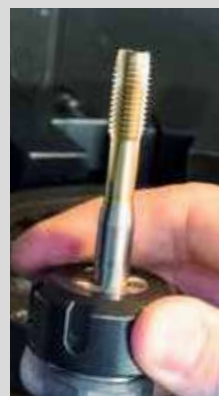

Maschiatura

Tapping

Per le operazioni di maschiatura, tutti i nostri motorizzati possono utilizzare pinze compensate ET-1 perfettamente intercambiabili con le normali pinze secondo norma DIN 6499. Esse consentono una compensazione assiale da 7 a 13 mm a seconda della grandezza per recuperare eventuali errori di avanzamento e per l'inversione della rotazione.

For tapping operations all driven tools can be equipped with axially compensated collets ET-1 interchangeable with the standard ER collets according the international standard DIN 6499. They allow the tap an axial compensation from 7 to 13 mm according to their size in order to compensate any feed error and the inversion of the rotation of direction.



Cuscinetti

Ball Bearings

Cuscinetti di precisione a contatto obliquo, precaricati e lubrificati con grasso a vita.

Preloaded angular contact ball bearings precision and long life lubrication.



Ingranaggi Gleason

Gleason Spiral bevel gears

Coppia conica di ingranaggi spirodali Gleason con evolvente rettificato ottimizzato

Gleason spiral bevel gears with completely ground involute form

I portautensili motorizzati per centri di tornitura a controllo numerico consentono di eseguire lavorazioni di fresatura, foratura e maschiatura sul tornio stesso e senza ulteriori piazzamenti. Anche in questo caso Gerardi propone un'ampia gamma di modelli, adatti ad attrezzare i torni e le torrette motorizzate dei maggiori costruttori di torni a livello mondiale con un rapporto qualità/prezzo insuperabile.

Driven tools for CNC turning centres allows milling, drilling and tapping operations on the lathes without additional parts handling. Also in this case Gerardi can supply a wide range of types in order to equip the CNC lathes and turrets of the most popular builders on the market with an unbeatable price/quality ratio.

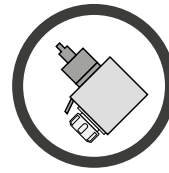

SCAN THE QR CODE



AND FIND OUT MORE



Scegli il modello più adatto alla tua lavorazione!

Choose the right model to have the best machining!



Refrigerante Interno
Internal Coolant

Tutti i motorizzati possono essere forniti con passaggio refrigerante attraverso l'albero utensile fino a 100bar.

All the driven tools, can be supplied with coolant feed through the spindle with rotating distributor upto 100 bar.

Corpo portautensili a sezione maggiorata per garantire maggior rigidità e minor vibrazioni
Re-designed main body to improve rigidity and reduce vibration.

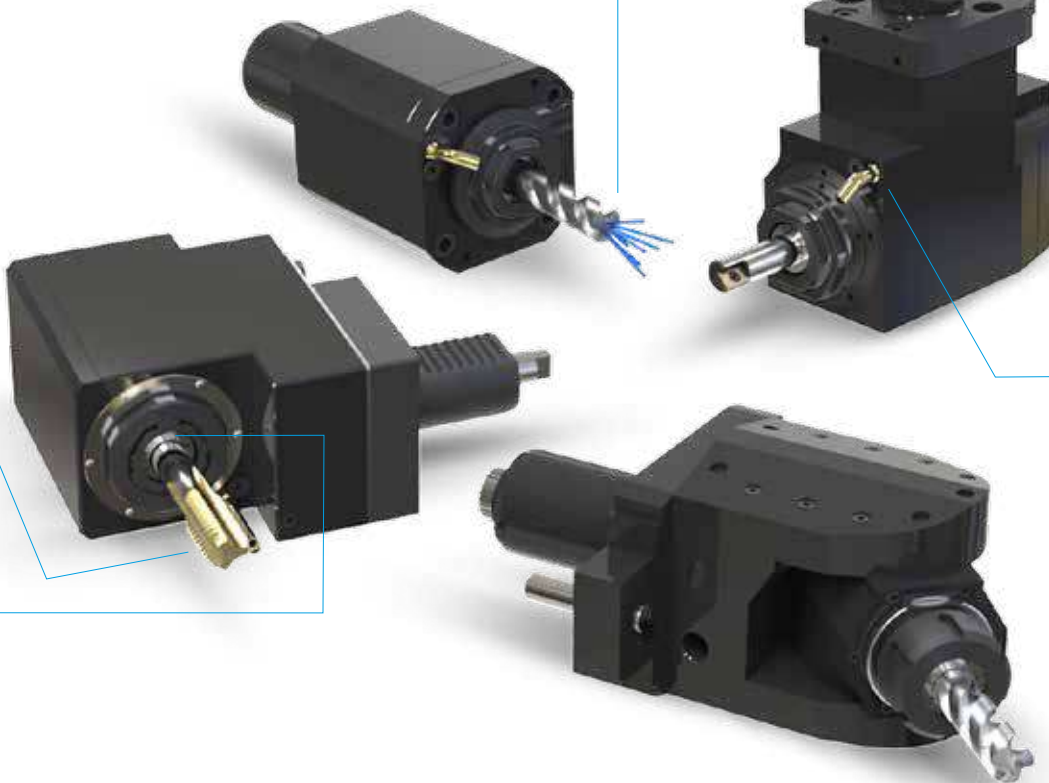

Refrigerante esterno
10 BAR standard
External Coolant
10 BAR standard

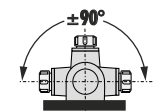

TORRETTE UNIFICATE VDI:
VDI LATHES TURRETS:

DIN 5480



DIN 5482



BARUFFALDI



DIN 1809



DENOMINAZIONE UTENSILE TOOL DESIGNATION

Montaggio TANGENZIALE - OD Mounting

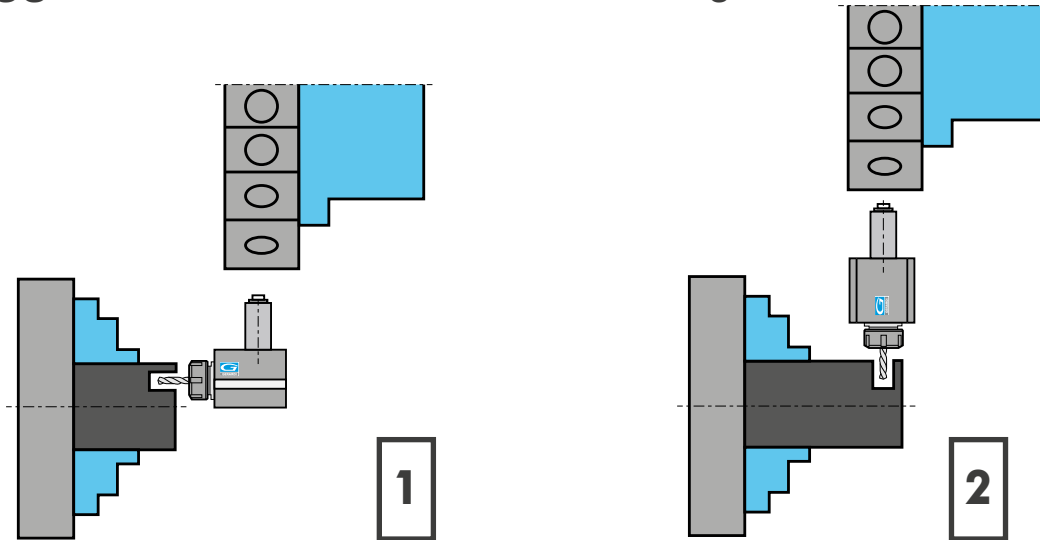

1 Motorizzato **RADIALE** per lavorazioni assiali
RADIAL driven tool for axial machining

2 Motorizzato **ASSIALE** per lavorazioni radiali
AXIAL driven tool heads for radial machining

Montaggio FRONTALE - FACE Mounting

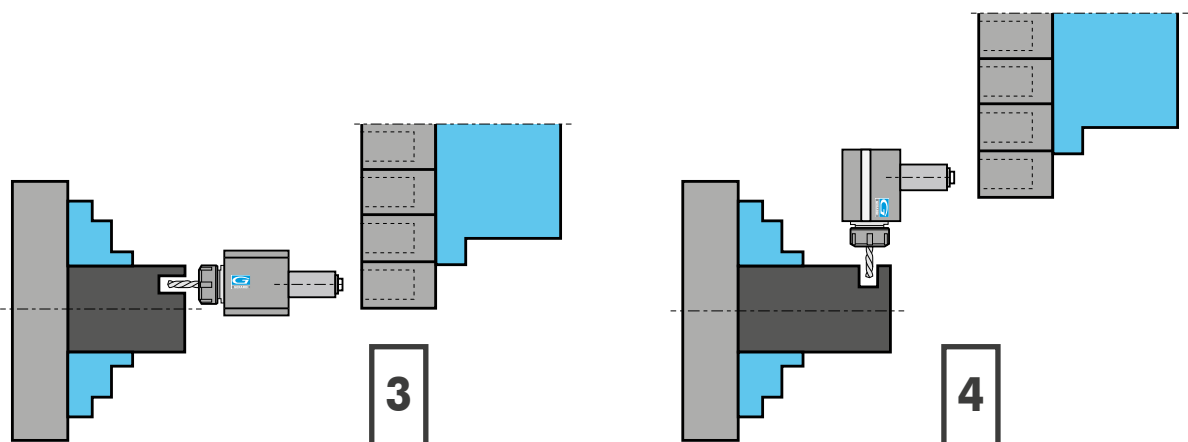

3 Motorizzato **ASSIALE** per lavorazioni assiali
AXIAL driven tool for axial machining

4 Motorizzato **RADIALE** per lavorazioni radiali
RADIAL driven tool heads for radial machining

MOTORIZZATI RADIALI PER LAVORAZIONI ASSIALI

RADIAL DRIVEN TOOLS FOR AXIAL MACHINING

Montaggio TANGENZIALE - OD Mounting

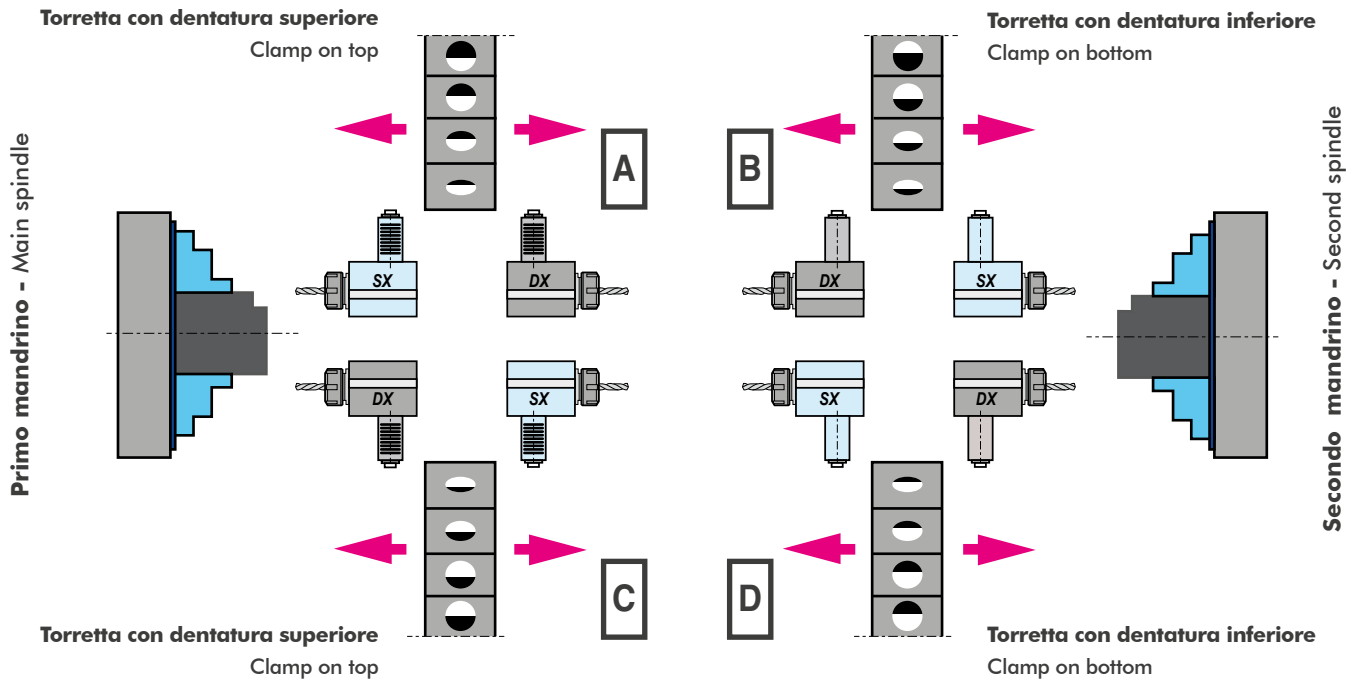

MOTORIZZATI RADIALI PER LAVORAZIONI RADIALI

RADIAL DRIVEN TOOLS FOR RADIAL MACHINING

Montaggio FRONTALE - FACE Mounting

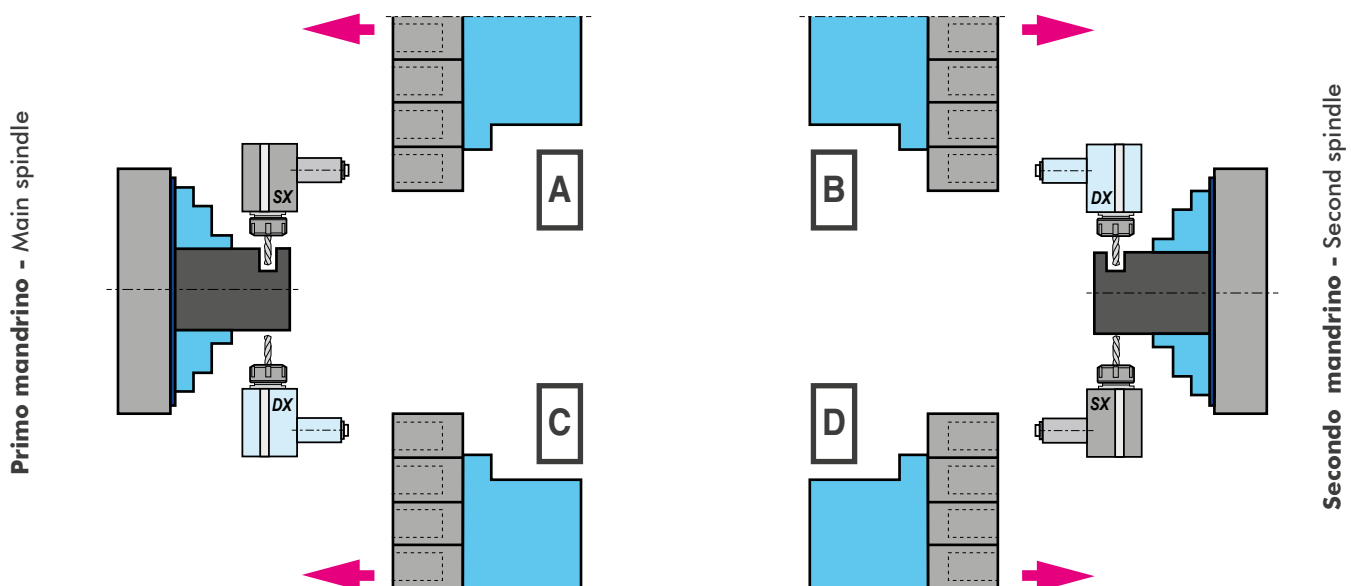



MODULAR QUICK CHANGE ADAPTORS



NEW
2021



COMPATIBILI CON TUTTE LE USCITE ER - COMPATIBLE WITH ALL ER OUTPUTS

SISTEMA MODULARE MODULAR SYSTEM



Facile e veloce sistema modulare universale per cambiare rapidamente diverse tipologie di utensili.

An easy modular system to replace quickly any tool you need.

VANTAGGI ADVANTAGES



Aiutano a ridurre i costi-extra per l'acquisto di nuovi motorizzati o teste angolari.

The costs for further requirements of spindle units can be reduced by using the universal quick change adaptors

ALTE PRESTAZIONI HIGH PERFORMANCE



Ghiera con cuscinetto a sfera e losanga di trascinamento removibile per una maggiore rigidità.

High rigidity thanks to the ball bearing nut and the removable diamond plate

COMPATIBILITÀ COMPATIBILITY



Ampia gamma di uscite disponibili adatte al montaggio su qualsiasi tipologia di motorizzato o testa angolare con uscita ER

Wide range of outputs available. Ball bearing nut and removable diamond plate for highest rigidity.

I cambi rapidi modulari Gerardi mantenendo il presetting precedentemente realizzato consentono un notevole risparmio dei costi ed un ottimizzazione dei tempi ciclo. Sono perfettamente compatibili con tutti i motorizzati e le teste angolari aventi uscita ER DIN6499 e possono essere utilizzati sia con refrigerante interno che esterno.

The Gerardi modular quick change adaptors keep the tool presetting previously made and allow great costs and machining times saving. They are perfectly compatible with all driven tools and angle head with ER DIN6499 output and they can be used with internal or external coolant.

- Nuovi cambi rapidi modulari 2.0 a FORTE SERRAGGIO, 100% Made in Italy.
- Prestazioni garantite e maggior rigidità sui motorizzati Gerardi grazie alla losanga di trascinamento (rimovibile) e alla ghiera con cuscinetto a sfera.
- Adattabili a motorizzati con uscita refrigerante sia interna che esterna.
- Si consiglia di non superare i 10.000 Rpm utilizzando i cambi rapidi

- Universal HIGH TORQUE modular quick change adaptor 100% Made in Italy.
- Guaranteed higher rigidity and performances on Gerardi driven tools thanks to the removable diamond plate and the ball bearing nut
- Suitable for ER toolholder with external and internal coolant supply
- Using the quick change adaptors, we suggest not to exceed 10.000 Rpm

CORPO CAMBIO RAPIDO 2.0
2.0 QUICK CHANGE BODY

GHIERA CON CUSCINETTO
BALL BEARING NUT

LOSANGA DI TRASCINAMENTO RIMOVIBILE
REMOVABLE DIAMOND PLATE
BREVETTO DEPOSITATO PATENT PENDING

10.000Rpm
MAX SUGGESTED

Vedi Pagine 7.12 - 7.15 - See pages 7.12 - 7.15



ER OUTPUTS COMPATIBLE



2 YEARS GUARANTEED



100% MADE IN ITALY

TORRETTA TIPO / TURRET TYPE
DIN69880 (VDI STANDARD)



DIN 5480

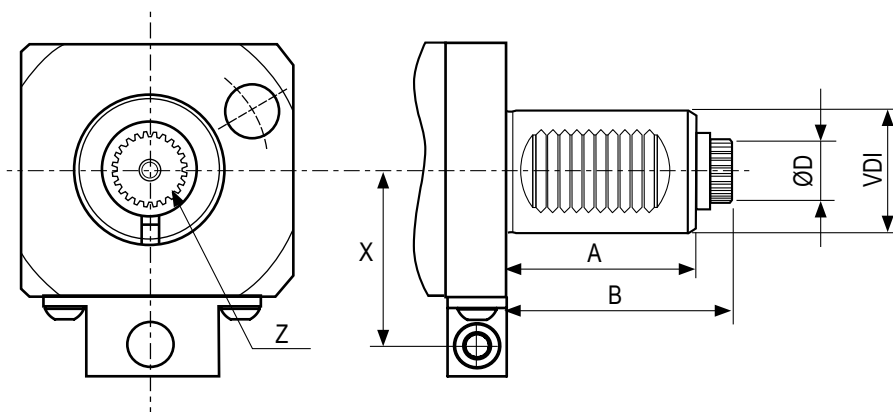

VDI	A	B	ØD	Z (N° denti - Teeth)	X
20	35	51	10,8	12	-
25	48	57	13,8	16	40
30	55	67	15,8	18	48
40	63	75	19,8	24	56
50	78	93	23,8	18	64



DOTAZIONE STANDARD
STANDARD EQUIPMENT

Chiave bloccaggio albero Art.179CH /
ugello refrigerazione Art.180 / vite bloccaggio ugello
Art.179CH shaft lock wrench /
cooling nozzle Art.180 / nozzle lock screws



CAMBI RAPIDI MODULARI Vedi pag. 7.12 - 7.15
MODULAR QUICK CHANGE See page 7.12 - 7.15

Facile e veloce sistema modulare per il cambio rapido delle diverse
tipologie di portautensili con la sede per pinza ER (DIN6499).
Modular toolholder system for the fitting of toolholders in
a spindle unit with ER collets (DIN6499) outputs.

MODELLI DI TORNIO COMPATIBILI
COMPATIBLE LATHE TYPES

VDI 20 / VDI 30 / VDI 40 / VDI 50 / VDI 60

Vedi pagine compatibilità 5.10 / 5.11 - See compatibility pages 5.10 / 5.11



VDI
DIN 5480

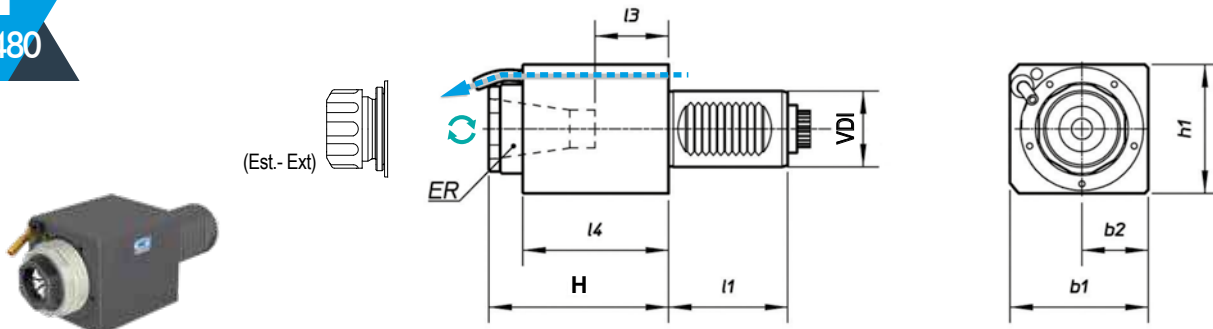

TIPO - TYPE
Assiale - Axial

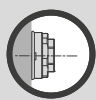

USCITA - OUTPUT
Porta Pinza
Collet Chuck

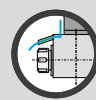

REFRIGERANTE
COOLANT
Esterno
External



RATIO
1:1



ROTAZIONE - ROTATION
Uguale al mandrino
Same as machine spindle

Code	VDI	Output	Int Cool.	l1	H	l3	l4	b1	b2	h1	Nm	Rpm	kw
99.ST.8002	25	ER-25 - Ø1+16	NO	48	69	21	54,5	54	27	56	20	6.000	6
99.ST.8003	30	ER-25 - Ø1+16	NO	55	66	21	59	62	31	64	32	6.000	8
99.ST.8004	30	ER-25 - Ø1+16	NO	55	94	39	88	62	31	64	32	6.000	8
99.ST.8005	40	ER-32 - Ø2+20	NO	63	95	34	77	73	35	70	63	6.000	10
99.ST.8006	40	ER-32 - Ø2+20	NO	63	115	54	97	73	35	70	63	6.000	10
99.ST.8007	50	ER-40 - Ø3+30	NO	78	88	25	69	88	44	88	100	4.000	12
99.ST.8008	50	ER-40 - Ø3+30	NO	78	120	45	102	88	44	88	100	4.000	12
♦ 99.ST.80101	60	ER-40 - Ø3+26	NO	94	148,7	54	127	111	55,5	111	160	3.200	16
♦ 99.ST.80120	60	ER50 (Est.- Ext)	NO	94	169,9	-	-	110	55	110	160	3.200	16

4

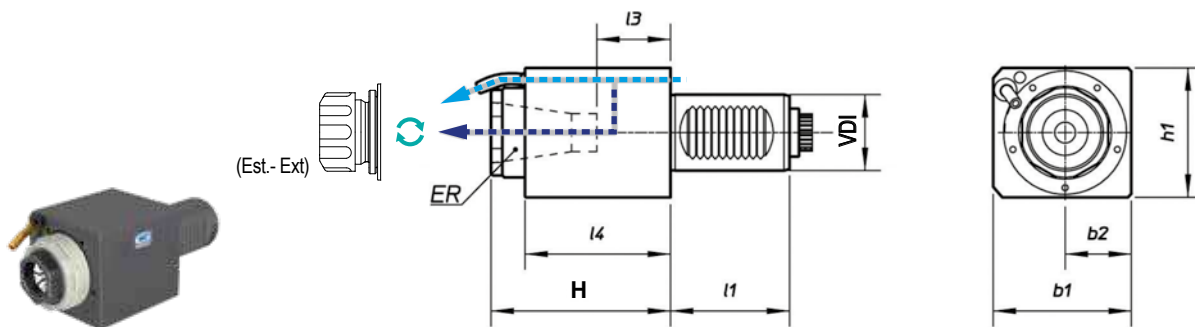

TIPO - TYPE
Assiale - Axial



USCITA - OUTPUT
Porta Pinza
Collet Chuck



REFRIGERANTE
COOLANT
25BAR



RATIO
1:1



ROTAZIONE - ROTATION
Uguale al mandrino
Same as machine spindle

Code	VDI	Output	Int Cool.	l1	H	l3	l4	b1	b2	h1	Nm	Rpm	kw
99.ST.8010	25	ER-25 - Ø1+16	✓	48	89	41,5	74	54	27	56	32	6.000	6
99.ST.8011	30	ER-25 - Ø1+16	✓	55	66	21	59	62	31	64	32	6.000	8
99.ST.8012	30	ER-25 - Ø1+16	✓	55	94	39	88	62	31	64	32	6.000	8
99.ST.8013	40	ER-32 - Ø2+20	✓	63	95	34	77	73	35	70	63	6.000	10
99.ST.8014	40	ER-32 - Ø2+20	✓	63	115	54	97	73	35	70	63	6.000	10
99.ST.8015	50	ER-40 - Ø3+30	✓	78	120	45	102	88	44	88	100	4.000	12
99.ST.8016	50	ER-40 - Ø3+30	✓	78	155	45	112	88	44	88	100	4.000	12
♦ 99.ST.80121	60	ER-50 (Est.- Ext)	✓ (80bar)	94	169,9	-	-	110	55	110	160	3.200	16

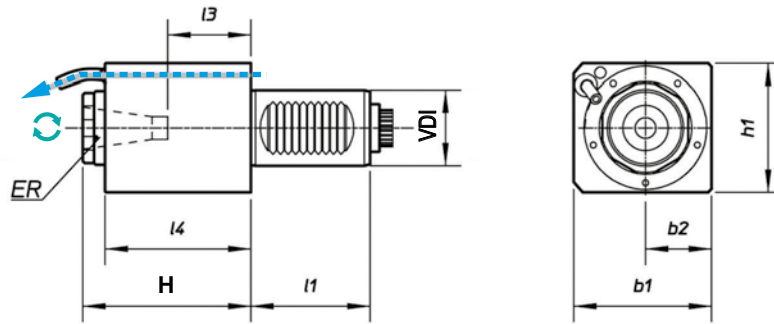

Vedi pagine compatibilità 5.10 / 5.11 - See compatibility pages 5.10 / 5.11

VDI
DIN 5480
NEW
2021

	TIPO - TYPE Assiale - Axial		USCITA - OUTPUT Porta Pinza Collet Chuck		REFRIGERANTE COOLANT Esterno External		RATIO 1:4		ROTAZIONE - ROTATION Uguale al mandrino Same as machine spindle
--	---------------------------------------	--	--	--	--	--	---------------------	--	---

Code	VDI	Output	Int Cool.	l1	H	l3	l4	b1	b2	h1	Nm	Rpm	kw
99.ST.8018	25	ER-16 - Ø1+10	NO	48	98,5	60,5	89,5	54	27	56	5	24.000	3
99.ST.8019	30	ER-16 - Ø1+10	NO	-	100	-	-	62	31	64	32	20.000	-
99.ST.8020	40	ER-20 - Ø1+13	NO	63	112,5	74,5	106	76	38	76	16	16.000	5
99.ST.8021	50	ER-20 - Ø1+13	NO	78	128,5	88,5	122	88	44	88	25	16.000	6

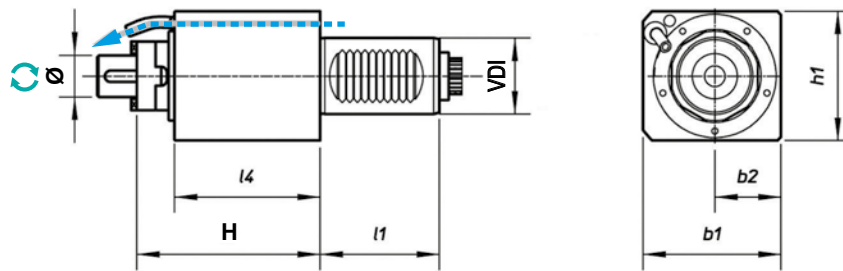
4

	TIPO - TYPE Assiale - Axial		USCITA - OUTPUT Porta Fresa Shell End Milling Cutter		REFRIGERANTE COOLANT Esterno External		RATIO 1:1		ROTAZIONE - ROTATION Uguale al mandrino Same as machine spindle
--	---------------------------------------	--	--	--	--	--	---------------------	--	---

Code	VDI	Output	Int Cool.	l1	H	l4	b1	b2	h1	Nm	Rpm	kw
99.ST.8023	25	Ø16	NO	48	110,5	89,5	54	27	56	20	6.000	6
99.ST.8024	30	Ø22	NO	55	112	88	62	31	64	32	6.000	8
99.ST.8025	40	Ø22	NO	63	102	77	73	35	70	63	6.000	10
99.ST.8026	50	Ø22	NO	78	138	112	88	44	88	100	6.000	12
99.ST.8027	50	Ø27	NO	78	138	112	88	44	88	100	4.000	12

MODELLI DI TORNIO COMPATIBILI
COMPATIBLE LATHE TYPES

VDI 20 / VDI 30 / VDI 40 / VDI 50 / VDI 60



Vedi pagine compatibilità 5.10 / 5.11 - See compatibility pages 5.10 / 5.11

VDI
DIN 5480

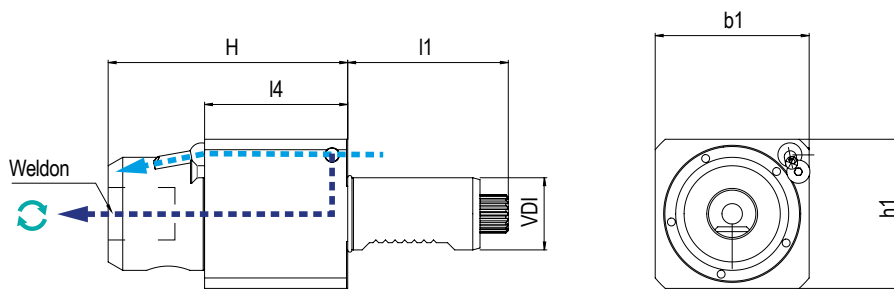

NEW
2021

	TIPO - TYPE Assiale - Axial		USCITA - OUTPUT Weldon		REFRIGERANTE COOLANT 25BAR		RATIO 1:1		ROTAZIONE - ROTATION Uguale al mandrino Same as machine spindle
--	---------------------------------------	--	----------------------------------	--	---	--	---------------------	--	--

Code	VDI	Output	Int Cool.	I1	H	I4	b1	h1	Nm	Rpm	kw	
99.ST.80103	30	Weldon Ø20	NO	66,7	99,59	59,5	64	62	32	5.000	8	
99.ST.80104	30	Weldon Ø20	✓	66,7	99,59	59,5	64	62	32	5.000	8	
99.ST.80105	30	Weldon Ø16	NO	66,7	99,59	59,5	64	62	32	5.000	8	
99.ST.80106	30	Weldon Ø16	✓	66,7	99,59	59,5	64	62	32	5.000	8	

4

MODELLI DI TORNIO COMPATIBILI
 COMPATIBLE LATHE TYPES

VDI 20 / VDI 30 / VDI 40 / VDI 50 / VDI 60

Vedi pagine compatibilità 5.10 / 5.11 - See compatibility pages 5.10 / 5.11

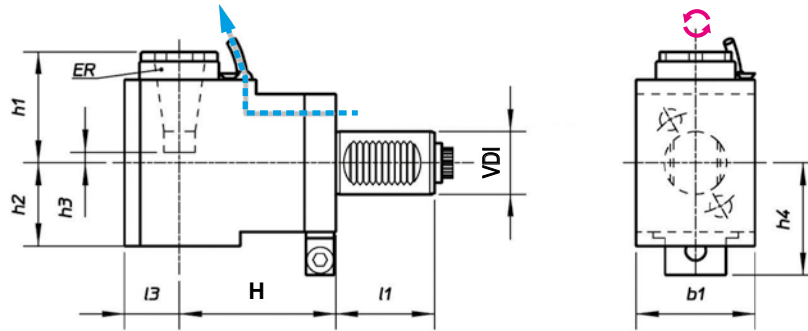
VDI
DIN 5480

 TIPO - TYPE
Radiale - Radial

 USCITA - OUTPUT
**Porta Pinza
 Collet Chuck**

 REFRIGERANTE
 COOLANT
**Esterno
 External**

 RATIO
1:1

 ROTAZIONE - ROTATION
**Opposto al mandrino
 Opposite to machine spindle**

Code	VDI	Output	Int Cool.	l1	H	l3	b1	h1	h2	h3	h4	Nm	Rpm	kw
99.ST.8029	25	ER-25 - Ø1+16	NO	48	75	28	54	50,5	42	4	48	20	6.000	6
99.ST.8030	30	ER-25 - Ø1+16	NO	55	55	31	64	56	48	3	54	32	6.000	8
99.ST.8031	30	ER-25 - Ø1+16	NO	55	85	31	64	56	48	3	54	32	6.000	8
99.ST.8032	30	ER-25 - Ø1+16	NO	55	100	31	64	56	48	3	54	32	6.000	8
99.ST.8033	40	ER-32 - Ø2+20	NO	63	100	35	76	71	55	11	71	63	6.000	10
99.ST.8034	40	ER-32 - Ø2+20	NO	63	120	35	76	71	55	11	71	63	6.000	10
99.ST.8035	50	ER-40 - Ø3+30	NO	78	110	44	88	92	73	16	79	100	4.000	12

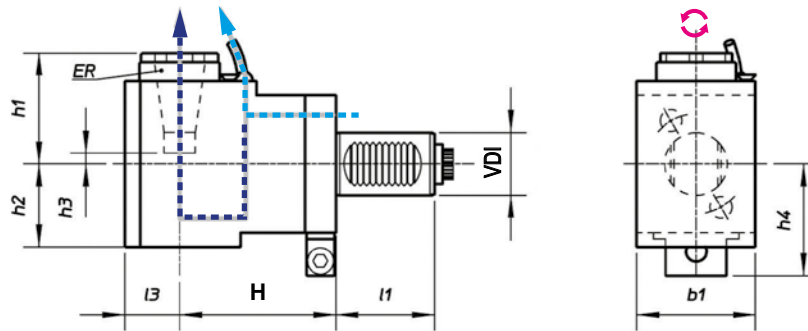
 TIPO - TYPE
Radiale - Radial

 USCITA - OUTPUT
**Porta Pinza
 Collet Chuck**

 REFRIGERANTE
 COOLANT
25BAR

 RATIO
1:1

 ROTAZIONE - ROTATION
**Opposto al mandrino
 Opposite to machine spindle**

Code	VDI	Output	Int Cool.	l1	H	l3	b1	h1	h2	h3	h4	Nm	Rpm	kw
99.ST.8037	25	ER-25 - Ø1+16	✓	48	75	28	54	60	61	4	48	20	6.000	6
99.ST.8038	30	ER-25 - Ø1+16	✓	55	55	31	64	56	60	2	54	32	6.000	8
99.ST.8039	30	ER-25 - Ø1+16	✓	55	85	31	64	56	60	2	54	32	6.000	8
99.ST.8040	30	ER-25 - Ø1+16	✓	55	100	31	64	56	60	2	54	32	6.000	8
99.ST.8041	40	ER-32 - Ø2+20	✓	63	100	35	76	71	62	11	71	63	6.000	10
99.ST.8042	40	ER-32 - Ø2+20	✓	63	120	35	76	71	73	11	71	63	6.000	10
99.ST.8043	50	ER-40 - Ø3+30	✓	78	110	44	88	92	73	16	79	100	4.000	12

MODELLI DI TORNIO COMPATIBILI
COMPATIBLE LATHE TYPES

VDI 20 / VDI 30 / VDI 40 / VDI 50 / VDI 60



Vedi pagine compatibilità 5.10 / 5.11 - See compatibility pages 5.10 / 5.11

VDI
DIN 5480

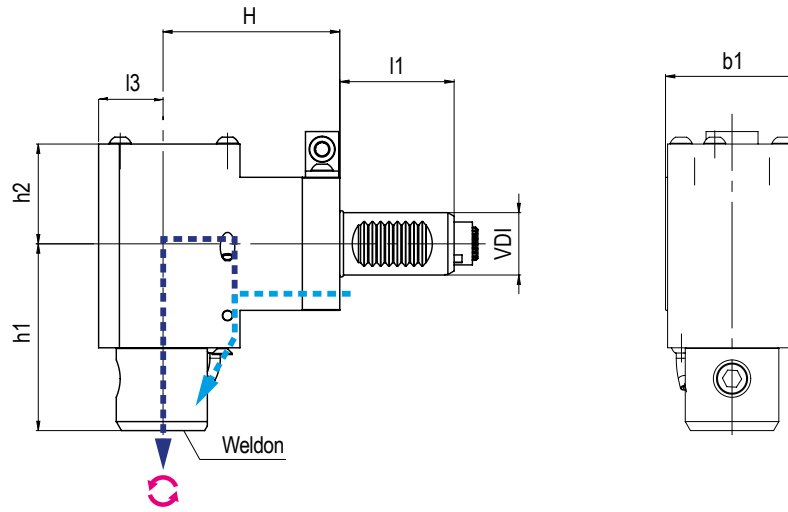

NEW
2021



TIPO - TYPE
Radiale - Radial



USCITA - OUTPUT
Weldon



REFRIGERANTE
COOLANT
25BAR



RATIO
1:1



ROTAZIONE - ROTATION
**Opposto al mandrino
Opposite to machine spindle**

Code	VDI	Output	Int Cool.	I1	H	I3	b1	h1	h2	Nm	Rpm	kw	
99.ST.80107	30	Weldon Ø20	NO	55	85	31	64	89,8	48	60	10.000	10	
99.ST.80108	30	Weldon Ø20	✓	55	85	31	64	89,8	59,7	60	10.000	10	
99.ST.80109	30	Weldon Ø16	NO	55	85	31	64	89,9	48	60	10.000	10	
99.ST.80110	30	Weldon Ø16	✓	55	85	31	64	89,9	59,7	60	10.000	10	

4

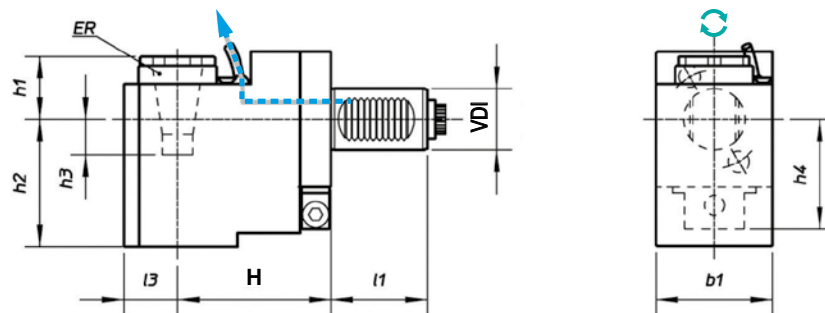

TIPO - TYPE
**Arretrato
Rear Offset**



USCITA - OUTPUT
**Porta Pinza
Collet Chuck**



REFRIGERANTE
COOLANT
**Esterno
External**



RATIO
1:1



ROTAZIONE - ROTATION
**Uguale al mandrino
Same as machine spindle**

Code	VDI	Output	Int Cool.	I1	H	I3	b1	h1	h2	h3	h4	Nm	Rpm	kw	
99.ST.8045	25	ER-20 - Ø1÷13	NO	48	75	28	54	13,5	79	41	48	20	6.000	6	
99.ST.8046	30	ER-25 - Ø1÷16	NO	55	85	31	64	21	90	45	56	32	5.000	8	
99.ST.8047	30	ER-25 - Ø1÷16	NO	55	100	31	64	21	90	45	56	32	5.000	8	
99.ST.8048	40	ER-32 - Ø2÷20	NO	63	100	35	76	20	106	40	65,5	63	6.000	10	
99.ST.8049	50	ER-40 - Ø3÷30	NO	78	110	44	88	31	123	44	73,5	100	4.000	12	

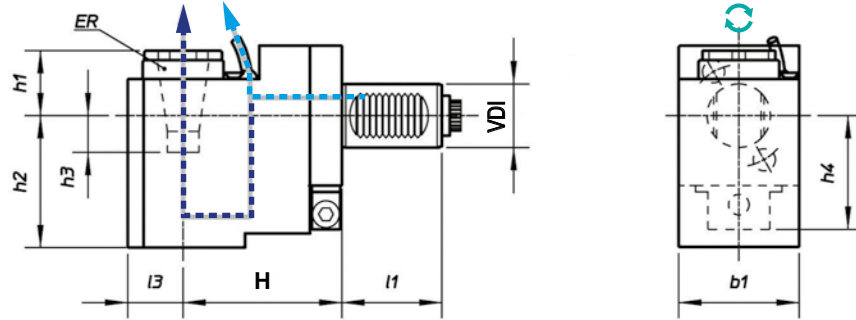

Vedi pagine compatibilità 5.10 / 5.11 - See compatibility pages 5.10 / 5.11

VDI
DIN 5480

 TIPO - TYPE
Arretrato
 Rear Offset

 USCITA - OUTPUT
Porta Pinza
 Collet Chuck

 REFRIGERANTE
 COOLANT
25BAR

 RATIO
1:1

 ROTAZIONE - ROTATION
Uguale al mandrino
 Same as machine spindle

Code	VDI	Output	Int Cool.	l1	H	l3	b1	h1	h2	h3	h4	Nm	Rpm	kw
99.ST.8051	25	ER-20 - Ø1÷13	✓	48	75	28	54	23	98	41	48	20	6.000	6
99.ST.8052	30	ER-25 - Ø1÷16	✓	55	85	31	64	24	105,5	45,5	56	32	5.000	8
99.ST.8053	30	ER-25 - Ø1÷16	✓	55	100	31	64	24	105,5	45,5	56	32	5.000	8
99.ST.8054	40	ER-32 - Ø2÷20	✓	63	100	35	76	30	124	40	65,5	63	6.000	10
99.ST.8055	50	ER-40 - Ø3÷30	✓	78	110	44	88	44	140,5	44	80,5	100	4.000	12

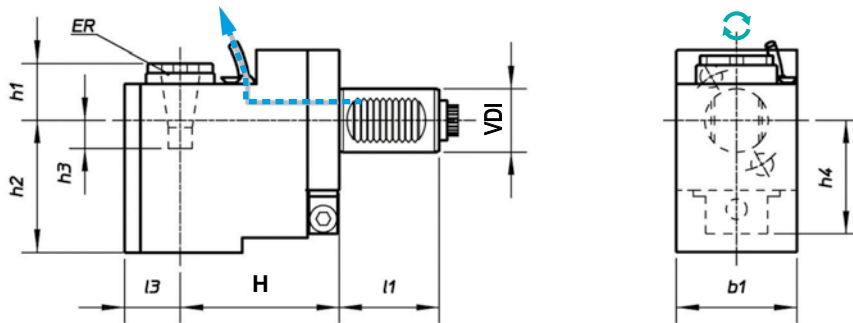
 TIPO - TYPE
Arretrato
 Rear Offset

 USCITA - OUTPUT
Porta Pinza
 Collet Chuck

 REFRIGERANTE
 COOLANT
Esterno
 External

 RATIO
1:4

 ROTAZIONE - ROTATION
Uguale al mandrino
 Same as machine spindle

Code	VDI	Output	Int Cool.	l1	H	l3	b1	h1	h2	h3	h4	Nm	Rpm	kw
99.ST.8057	25	ER-16 - Ø1÷10	NO	48	90	21	54	31	81	11	48	5	24.000	3
99.ST.8058	30	ER-16 - Ø1÷10	NO	55	95	21	64	33	84	15	56	8	21.000	4
99.ST.8059	40	ER-20 - Ø1÷13	NO	63	125	27	76	45	108	10	65,5	16	16.000	5
99.ST.8060	50	ER-20 - Ø1÷13	NO	78	135	27	86	45	113	10	73,5	25	16.000	6

MODELLI DI TORNIO COMPATIBILI
COMPATIBLE LATHE TYPES

VDI 20 / VDI 30 / VDI 40 / VDI 50 / VDI 60



Vedi pagine compatibilità 5.10 / 5.11 - See compatibility pages 5.10 / 5.11

VDI
DIN 5480

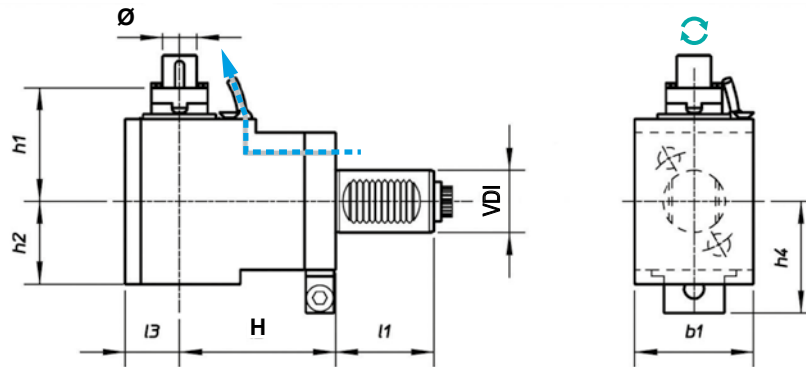

TIPO - TYPE
Radiale
Radial



USCITA - OUTPUT
Porta Fresa
Shell End Milling Cutter



REFRIGERANTE
COOLANT
Esterno
External



RATIO
2:1



ROTAZIONE - ROTATION
Uguale al mandrino
Same as machine spindle

Code	VDI	Output	Int Cool.	l1	H	l3	b1	h1	h2	h4	Nm	Rpm	kw
99.ST.8070	25	Ø16	NO	48	75	28	54	66	48	48	40	3.000	6
99.ST.8071	30	Ø22	NO	55	55	31	64	74	48	56	63	2.500	8
99.ST.8072	30	Ø22	NO	55	85	31	64	74	48	56	63	2.500	8
99.ST.8073	30	Ø22	NO	55	100	31	64	74	48	56	63	2.500	8
99.ST.8074	40	Ø22	NO	63	100	35	76	78	55	65,5	63	3.000	8
99.ST.8075	40	Ø22	NO	63	120	35	76	78	55	65,5	63	3.000	8
99.ST.8076	50	Ø27	NO	78	110	44	88	110	62	73,5	100	2.000	12

4

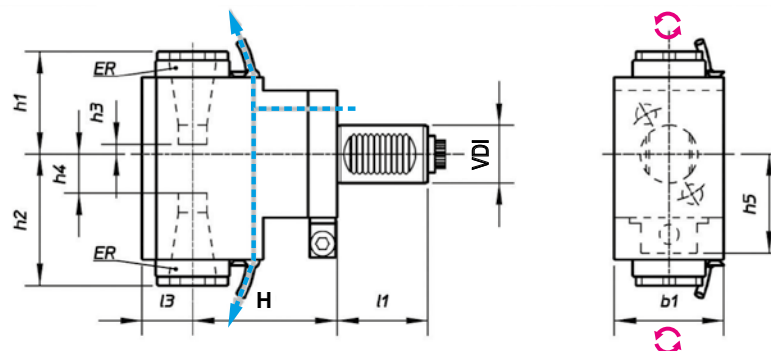

TIPO - TYPE
Radiale Doppio
Double Radial



USCITA - OUTPUT
Porta Pinza
Collet Chuck



REFRIGERANTE
COOLANT
Esterno
External



RATIO
1:1



ROTAZIONE - ROTATION
Opposto al mandrino
Opposite to machine spindle

Code	VDI	Output	Int Cool.	l1	H	l3	b1	h1	h2	h3	h4	h5	Nm	Rpm	kw
99.ST.8078	25	ER-20 - Ø1+13	NO	48	75	28	54	50,5	71,5	4	32	48	20	6.000	6
99.ST.8079	30	ER-25 - Ø1+16	NO	55	85	31	64	63	84	2,5	22,5	56	32	5.000	8
99.ST.8080	30	ER-25 - Ø1+16	NO	55	100	31	64	63	84	2,5	22,5	56	32	5.000	8
99.ST.8081	40	ER-32 - Ø2+20	NO	63	100	35	76	71	96	11	36,5	65,5	63	6.000	10
99.ST.8082	40	ER-32 - Ø2+20	NO	63	120	35	76	71	96	11	36,5	65,5	63	6.000	10

MODELLI DI TORNIO COMPATIBILI
 COMPATIBLE LATHE TYPES

VDI 20 / VDI 30 / VDI 40 / VDI 50 / VDI 60

Vedi pagine compatibilità 5.10 / 5.11 - See compatibility pages 5.10 / 5.11

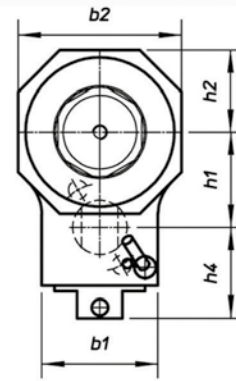
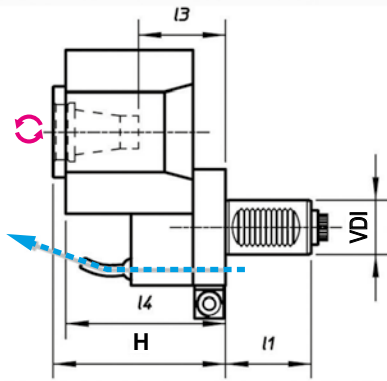
VDI
DIN 5480
NEW
2021

 TIPO - TYPE
Disassato
 Offset Axis

 USCITA - OUTPUT
Porta Pinza
 Collet Chuck

 REFRIGERANTE
 COOLANT
Esterno
 External

 RATIO
2:1

 ROTAZIONE - ROTATION
Opposto al mandrino
 Opposite to machine spindle

Code	VDI	Output	Int Cool.	l1	H	l4	b1	b2	h1	h2	h4	Nm	Rpm	kw
99.ST.8083	30	ER-25 - Ø1+16	NO	55	95	88	64	90	52,5	45	54	64	3.000	8
99.ST.80111	30	ER-32 - Ø2+20	NO	55	100,25	88	-	90	-	-	-	63	2.500	8
99.ST.80112	40	ER-32 - Ø2+20	NO	63	99	92	76	108	68,5	54	65,5	100	2.000	10

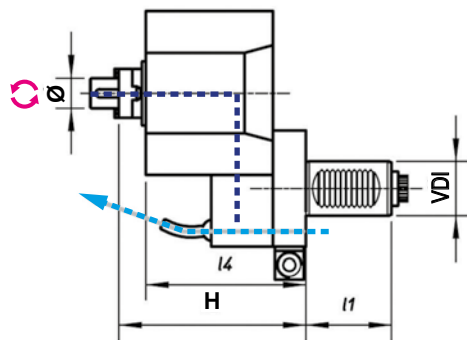
 TIPO - TYPE
Disassato
 Offset Axis

 USCITA - OUTPUT
Porta Fresa
 Shell End Milling Cutter

 REFRIGERANTE
 COOLANT
Esterno
 External

 RATIO
2:1

 ROTAZIONE - ROTATION
Opposto al mandrino
 Opposite to machine spindle

Code	VDI	Output	Int Cool.	l1	H	l4	b1	b2	h1	h2	h4	Nm	Rpm	kw
99.ST.8084	30	Ø22	NO	55	95	88	64	90	52,5	45	54	64	3.000	8
99.ST.8012A	40	Ø22	NO	63	117	92	76	108	68,5	54	65,5	100	2.000	10

MODELLI DI TORNIO COMPATIBILI
COMPATIBLE LATHE TYPES

VDI 20 / VDI 30 / VDI 40 / VDI 50 / VDI 60



Vedi pagine compatibilità 5.10 / 5.11 - See compatibility pages 5.10 / 5.11

VDI
DIN 5480

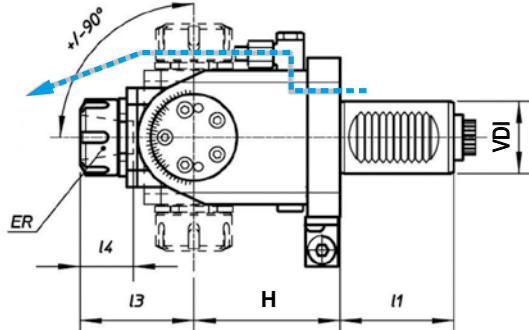
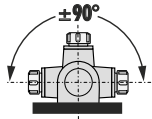

SINISTRO - LEFT
(Standard)

DESTRO - RIGHT
(Specify)

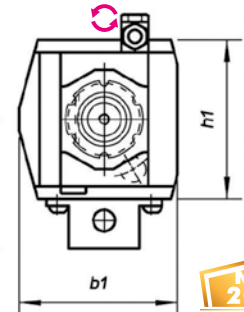
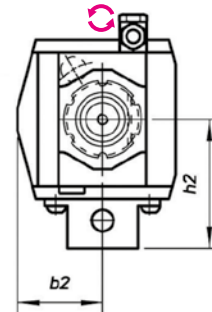

NEW
2021



TIPO - TYPE
Orientabile
Adjustable $\pm 90^\circ$



USCITA - OUTPUT
Porta Pinza
Collet Chuck



REFRIGERANTE
COOLANT
Esterno
External



RATIO
1:1



ROTAZIONE - ROTATION
Opposto al mandrino
Opposite to machine spindle

Code	VDI	Output	Int Cool.	l1	H	l3	l4	b1	b2	h1	h2	Nm	Rpm	kw
99.ST.80100	20	ER-16 - Ø1+10	NO	39,6	70	52	-	69,5	-	50	-	15	6.000	2
99.ST.8086	25	ER-16 - Ø1+10	NO	48	55	54	34,5	70,5	38	65	49,5	10	6.000	2
99.ST.8097	25	ER-20 - Ø1+13	NO	48	70	52	37	70	37	64	54	15	6.000	3
99.ST.8087	30	ER-20 - Ø1+13	NO	55	64	52	37	70	37	64	54	15	6.000	3
99.ST.8088	30	ER-20 - Ø1+13	NO	55	97	52	37	70	37	64	54	15	6.000	3
99.ST.8089	40	ER-25 - Ø1+16	NO	63	81	63	42	87	47	88	71	25	4.000	4
99.ST.8098	40	ER-25 - Ø1+16	NO	63	120	63	42	87	47	88	71	25	4.000	4
99.ST.8096	50	ER-32 - Ø2+20	NO	78	123	101	47	134	54	108	78	50	4.000	6

4

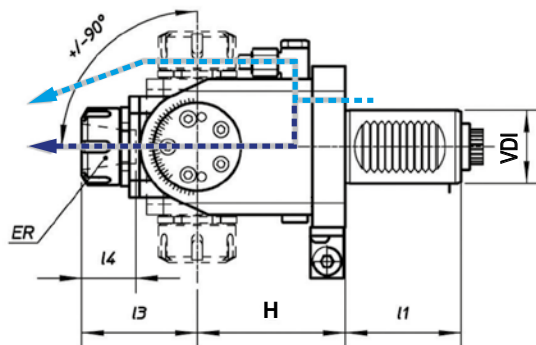
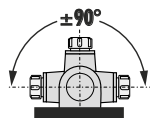

SINISTRO - LEFT
(Standard)

DESTRO - RIGHT
(Specify)

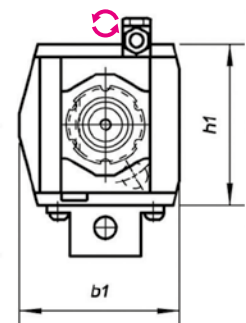
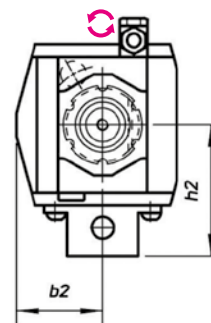

TIPO - TYPE
Orientabile
Adjustable $\pm 90^\circ$



USCITA - OUTPUT
Porta Pinza
Collet Chuck



REFRIGERANTE
COOLANT
25BAR



RATIO
1:1



ROTAZIONE - ROTATION
Opposto al mandrino
Opposite to machine spindle

Code	VDI	Output	Int Cool.	l1	H	l3	l4	b1	b2	h1	h2	h4	Nm	Rpm	kw
99.ST.8091	30	ER-20 - Ø1+13	✓	55	64	37	52	37	70	37	64	54	15	6.000	3
99.ST.8092	30	ER-20 - Ø1+13	✓	55	97	37	52	37	70	37	64	54	15	6.000	3
99.ST.8093	40	ER-25 - Ø1+16	✓	63	81	42	63	42	87	47	88	71	25	4.000	4

TORRETTA TIPO / TURRET TYPE
DIN69880 (VDI STANDARD)



DIN 5482



DIN 5480

BARUFFALDI

DIN 1809

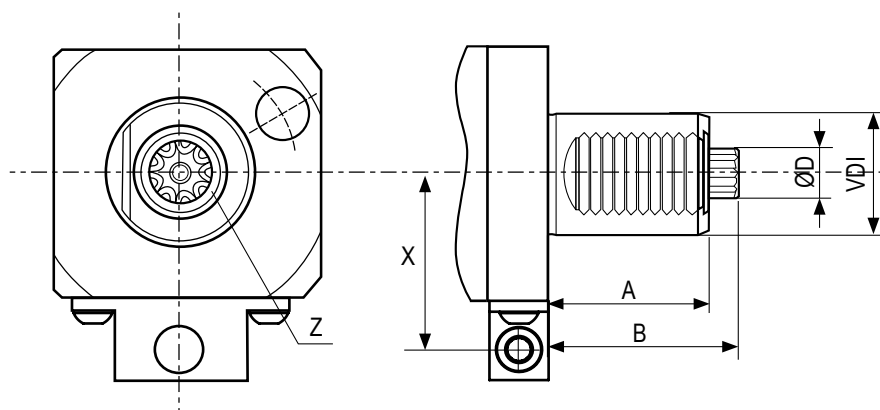

VDI	A	B	ØD	Z (N°denti - Teeth)	X
30	45	55	14,5	8	40
40	53	63	16,5	9	63
50	78	93	19,5	11	70
60	94	108	24,5	14	-

DOTAZIONE STANDARD
STANDARD EQUIPMENT

Chiave bloccaggio albero Art.179CH /
ugello refrigerazione Art.180 / vite bloccaggio ugello
Art.179CH shaft lock wrench /
cooling nozzle Art.180 / nozzle lock screws

CAMBI RAPIDI MODULARI Vedi pag. 7.12 - 7.15
MODULAR QUICK CHANGE See page 7.12 - 7.15

Facile e veloce sistema modulare per il cambio rapido delle diverse
tipologie di portautensili con la sede per pinza ER (DIN6499).
Modular toolholder system for the fitting of toolholders in
a spindle unit with ER collets (DIN6499) outputs.



MODELLI DI TORNIO COMPATIBILI
COMPATIBLE LATHE TYPES

VDI 20 / VDI 30 / VDI 40 / VDI 50 / VDI 60



Vedi pagine compatibilità 5.10 / 5.11 - See compatibility pages 5.10 / 5.11

VDI
DIN 5482

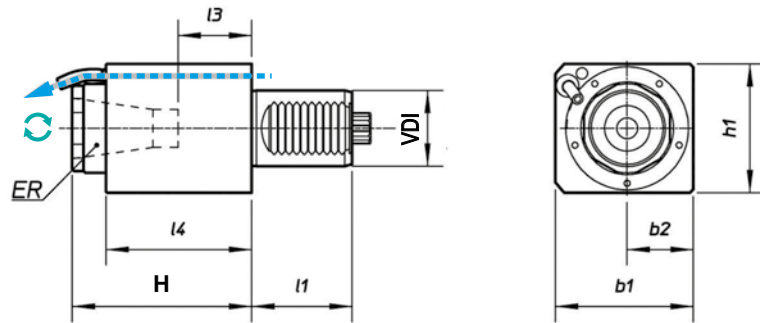

TIPO - TYPE
Assiale - Axial



USCITA - OUTPUT
Porta Pinza
Collet Chuck



REFRIGERANTE
COOLANT
Esterno
External



RATIO
1:1



ROTAZIONE - ROTATION
Uguale al mandrino
Same as machine spindle

Code	VDI	Output	Int Cool.	l1	H	l3	l4	b1	b2	h1	Nm	Rpm	kw	
99.ST.8201	30	ER-25 - Ø1+16	NO	45	94	39	88	62	31	64	32	6.000	8	
99.ST.8203	40	ER-32 - Ø2+20	NO	53	115	54	97	73	35	70	63	5.000	10	
99.ST.8205	50	ER-40 - Ø3+30	NO	78	150	75	142	88	44	88	100	4.000	12	
99.ST.8206	60	ER-50 - Ø7+34	NO	94	220	110	168	110	55	110	160	3.200	15	

4

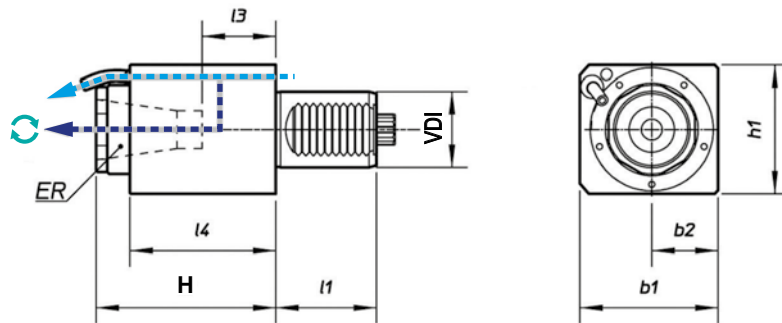

TIPO - TYPE
Assiale - Axial



USCITA - OUTPUT
Porta Pinza
Collet Chuck



REFRIGERANTE
COOLANT
25BAR



RATIO
1:1



ROTAZIONE - ROTATION
Uguale al mandrino
Same as machine spindle

Code	VDI	Output	Int Cool.	l1	H	l3	l4	b1	b2	h1	Nm	Rpm	kw	
99.ST.8207	30	ER-25 - Ø1+16	✓	45	94	39	88	62	31	64	32	6.000	8	
99.ST.8208	40	ER-32 - Ø2+20	✓	53	115	54	97	73	35	70	63	5.000	10	
99.ST.8210	50	ER-40 - Ø3+30	✓	78	133	45	112	88	44	88	100	4.000	12	
99.ST.8211	60	ER-50 - Ø7+34	✓	94	228	110	168	110	55	110	160	3.200	15	

MODELLI DI TORNIO COMPATIBILI
 COMPATIBLE LATHE TYPES

VDI 20 / VDI 30 / VDI 40 / VDI 50 / VDI 60

Vedi pagine compatibilità 5.10 / 5.11 - See compatibility pages 5.10 / 5.11

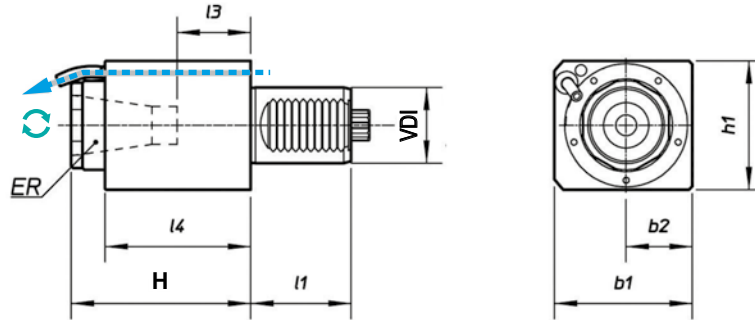
VDI
DIN 5482

 TIPO - TYPE
Assiale - Axial

 USCITA - OUTPUT
**Porta Pinza
Collet Chuck**

 REFRIGERANTE
 COOLANT
**Esterno
External**

 RATIO
1:4

 ROTAZIONE - ROTATION
**Uguale al mandrino
Same as machine spindle**

Code	VDI	Output	Int Cool.	l1	H	l3	l4	b1	b2	h1	Nm	Rpm	kw
99.ST.8212	30	ER-16 - Ø1+10	NO	45	100	58	88	62	31	64	8	20.000	4
99.ST.8213	40	ER-20 - Ø1+13	NO	53	112,5	74,5	106	76	38	76	16	16.000	5
99.ST.8214	50	ER-20 - Ø1+13	NO	78	128,5	88,5	122	88	44	88	25	16.000	6

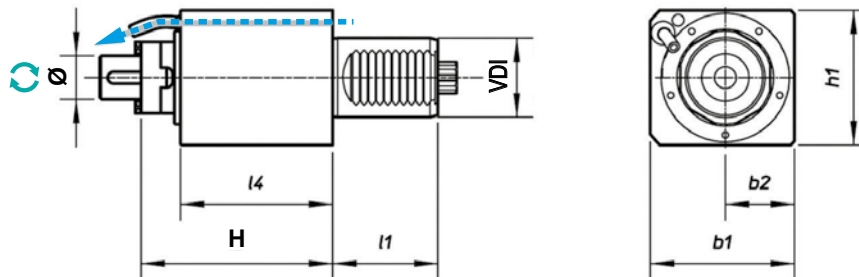
 TIPO - TYPE
Assiale - Axial

 USCITA - OUTPUT
**Porta Fresa
Shell End Milling Cutter**

 REFRIGERANTE
 COOLANT
**Esterno
External**

 RATIO
1:1

 ROTAZIONE - ROTATION
**Uguale al mandrino
Same as machine spindle**

Code	VDI	Output	Int Cool.	l1	H	l3	l4	b1	b2	h1	Nm	Rpm	kw
99.ST.8215	30	Ø22	NO	45	112		88	62	31	64	32	6.000	8
99.ST.8216	40	Ø22	NO	53	124		99	73	35	70	63	5.000	10

MODELLI DI TORNIO COMPATIBILI
COMPATIBLE LATHE TYPES

VDI 20 / VDI 30 / VDI 40 / VDI 50 / VDI 60

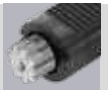

Vedi pagine compatibilità 5.10 / 5.11 - See compatibility pages 5.10 / 5.11

VDI
DIN 5482

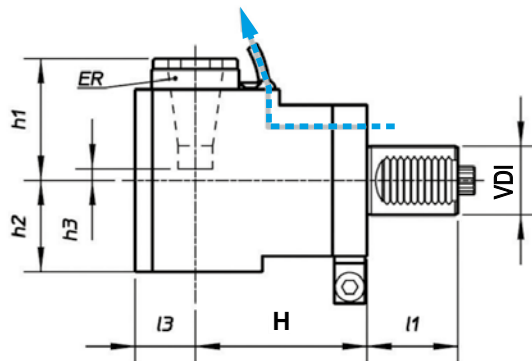

SINISTRO - LEFT
(Standard)

DESTRO - RIGHT
(Specify)

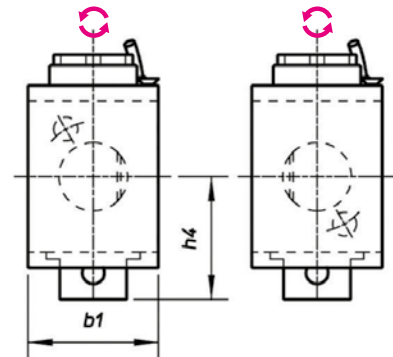

TIPO - TYPE
Radial - Radial



USCITA - OUTPUT
Porta Pinza Collet Chuck



REFRIGERANTE COOLANT
Esterno External



RATIO
1:1



ROTAZIONE - ROTATION
Opposto al mandrino Opposite to machine spindle

Code	VDI	Output	Int Cool.	I1	H	I3	b1	h1	h2	h3	h4	Nm	Rpm	kw
99.ST.8217	30	ER-25 - Ø1+16	NO	45	55	31	64	56	48	3	52	32	6.000	8
99.ST.8220	40	ER-32 - Ø2+20	NO	53	100	35	76	71	55	11	71	63	5.000	10
99.ST.8221	50	ER-40 - Ø3+30	NO	78	110	44	88	92	62	17	80,5	100	4.000	12
99.ST.8222	60	ER-50 - Ø7+34	NO	94	130	55	110	149	102	39	103	160	3.200	15

4

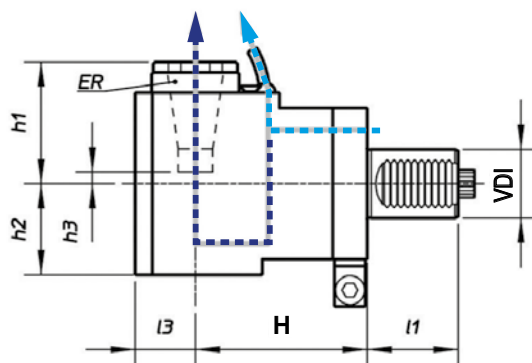

SINISTRO - LEFT
(Standard)

DESTRO - RIGHT
(Specify)

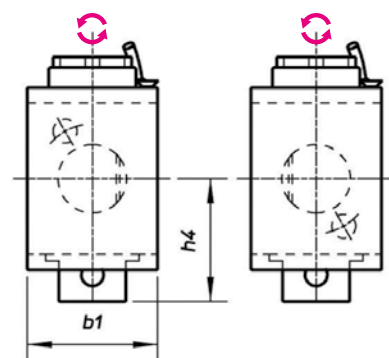

TIPO - TYPE
Radial - Radial



USCITA - OUTPUT
Porta Pinza Collet Chuck



REFRIGERANTE COOLANT
25BAR



RATIO
1:1



ROTAZIONE - ROTATION
Opposto al mandrino Opposite to machine spindle

Code	VDI	Output	Int Cool.	I1	H	I3	b1	h1	h2	h3	h4	Nm	Rpm	kw
99.ST.8223	30	ER-25 - Ø1+16	✓	45	55	31	64	56	60	2	52	32	6.000	8
99.ST.8226	40	ER-32 - Ø2+20	✓	53	100	35	76	71	62	11	71	63	5.000	10
99.ST.8227	50	ER-40 - Ø3+30	✓	78	110	44	88	105	79,5	17	80,5	100	4.000	12
99.ST.8228	60	ER-50 - Ø7+34	✓	94	130	55	110	157	102	39	103	160	3.200	15

MODELLI DI TORNIO COMPATIBILI
 COMPATIBLE LATHE TYPES

VDI 20 / VDI 30 / VDI 40 / VDI 50 / VDI 60

Vedi pagine compatibilità 5.10 / 5.11 - See compatibility pages 5.10 / 5.11

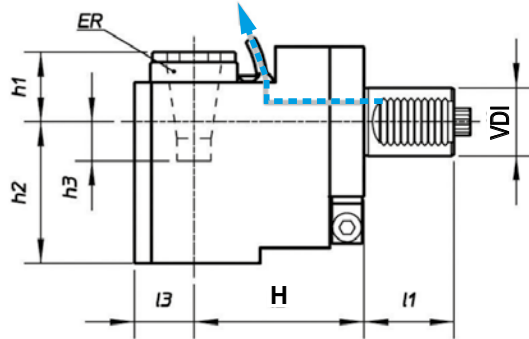
VDI
DIN 5482

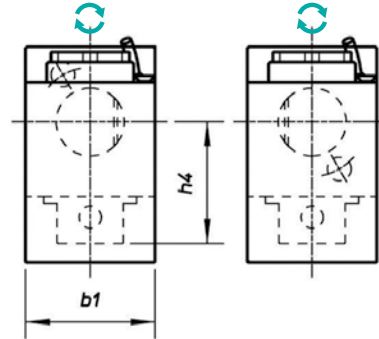
SINISTRO - LEFT
 (Standard)

DESTRO - RIGHT
 (Specify)

 TIPO - TYPE
Arretrato
 Rear Offset

 USCITA - OUTPUT
Porta Pinza
 Collet Chuck

 REFRIGERANTE
 COOLANT
Esterno
 External

 RATIO
1:1

 ROTAZIONE - ROTATION
Uguale al mandrino
 Same as machine spindle

Code	VDI	Output	Int Cool.	l1	H	l3	b1	h1	h2	h3	h4	Nm	Rpm	kw
99.ST.8229	30	ER-25 - Ø1+16	NO	45	85	31	64	14,5	90	45	52	32	6.000	8
99.ST.8230	40	ER-32 - Ø2+20	NO	53	100	35	76	20	106	40	72,5	63	5.000	10
99.ST.8231	50	ER-40 - Ø3+30	NO	78	110	44	88	31	123	44	80,5	100	4.000	12
99.ST.8232	60	ER-50 - Ø7+34	NO	94	135	55	110	67	184	43	103	160	3.200	15

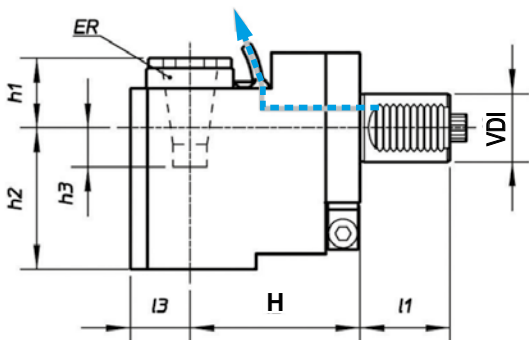
4

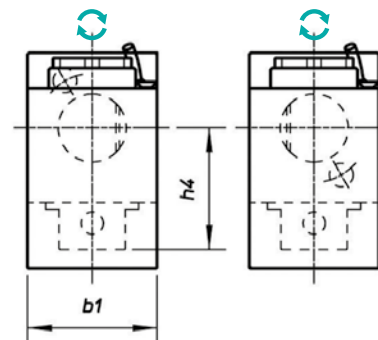
SINISTRO - LEFT
 (Standard)

DESTRO - RIGHT
 (Specify)

 TIPO - TYPE
Arretrato
 Rear Offset

 USCITA - OUTPUT
Porta Pinza
 Collet Chuck

 REFRIGERANTE
 COOLANT
25BAR

 RATIO
1:1

 ROTAZIONE - ROTATION
Uguale al mandrino
 Same as machine spindle

Code	VDI	Output	Int Cool.	l1	H	l3	b1	h1	h2	h3	h4	Nm	Rpm	kw
99.ST.8233	30	ER-25 - Ø1+16	✓	45	85	31	64	24	105,5	45,5	52	32	6.000	8
99.ST.8234	40	ER-32 - Ø2+20	✓	53	100	35	76	30	124	40	72,5	63	5.000	10
99.ST.8235	50	ER-40 - Ø3+30	✓	78	110	44	88	44	140,5	44	80,5	100	4.000	12

MODELLI DI TORNIO COMPATIBILI
COMPATIBLE LATHE TYPES

VDI 20 / VDI 30 / VDI 40 / VDI 50 / VDI 60



Vedi pagine compatibilità 5.10 / 5.11 - See compatibility pages 5.10 / 5.11

VDI
DIN 5482

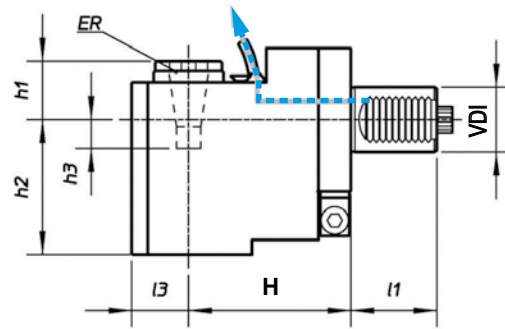

SINISTRO - LEFT
(Standard)

DESTRO - RIGHT
(Specify)

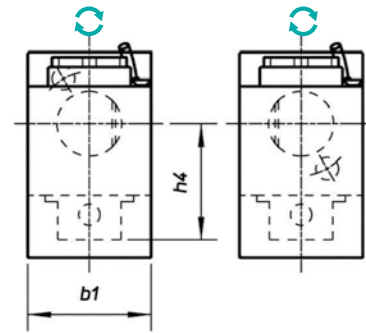

TIPO - TYPE
Arretrato
Rear Offset



USCITA - OUTPUT
Porta Pinza
Collet Chuck



REFRIGERANTE
COOLANT
Esterno
External



RATIO
1:4



ROTAZIONE - ROTATION
Ugualo al mandrino
Same as machine spindle

Code	VDI	Output	Int Cool.	I1	H	I3	b1	h1	h2	h3	h4	Nm	Rpm	kw
99.ST.8237	30	ER-16 - Ø1+10	NO	45	95	21	64	33	84	15	56	8	20.000	4
99.ST.8238	40	ER-20 - Ø1+13	NO	53	125	27	76	45	108	10	65,5	16	16.000	5
99.ST.8239	50	ER-20 - Ø1+13	NO	78	135	27	86	45	113	10	73,5	25	16.000	6

4

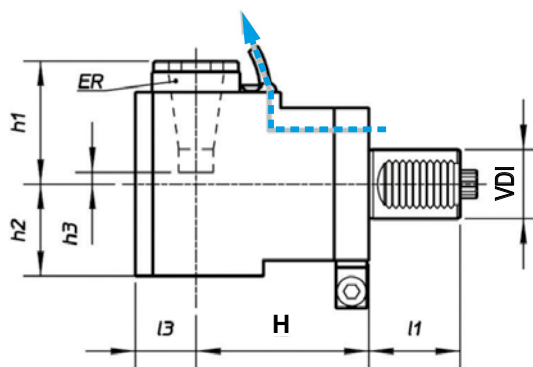

SINISTRO - LEFT
(Standard)

DESTRO - RIGHT
(Specify)

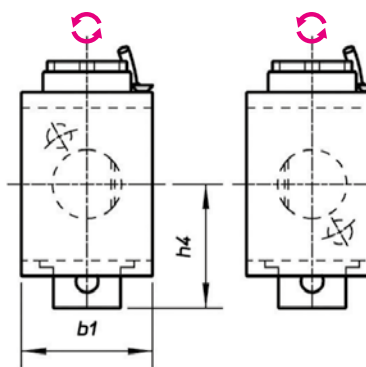

TIPO - TYPE
Radial - Radial



USCITA - OUTPUT
Porta Pinza
Collet Chuck



REFRIGERANTE
COOLANT
Esterno
External



RATIO
2:1



ROTAZIONE - ROTATION
Opposto al mandrino
Opposite to machine spindle

Code	VDI	Output	Int Cool.	I1	H	I3	km	h1	h2	h3	h4	Nm	Rpm	kw
99.ST.8240	30	ER-25 - Ø1+16	NO	45	55	31	64	56,5	48	3	52	63	2.500	8
99.ST.8241	40	ER-32 - Ø2+20	NO	53	100	35	76	71	55	-11	72,5	63	2.000	8

MODELLI DI TORNIO COMPATIBILI
 COMPATIBLE LATHE TYPES

VDI 20 / VDI 30 / VDI 40 / VDI 50 / VDI 60

Vedi pagine compatibilità 5.10 / 5.11 - See compatibility pages 5.10 / 5.11

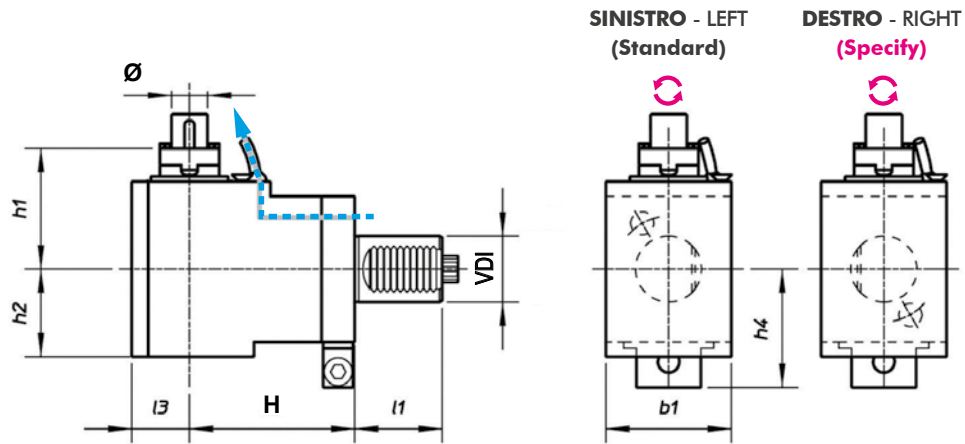
VDI
DIN 5482

 TIPO - TYPE
Radial - Radial

 USCITA - OUTPUT
Porta Fresa Shell End Milling Cutter

 REFRIGERANTE COOLANT
Esterno External

 RATIO
1:1

 ROTAZIONE - ROTATION
Opposto al mandrino Opposite to machine spindle

Code	VDI	Output	Int Cool.	l1	H	l3	b1	h1	h2	h4	Nm	Rpm	kw
99.ST.8242	30	Ø22	NO	45	55	31	64	74	48	52	63	2.500	8
99.ST.8243	40	Ø22	NO	53	100	35	76	78	55	72,5	63	2.000	8

4

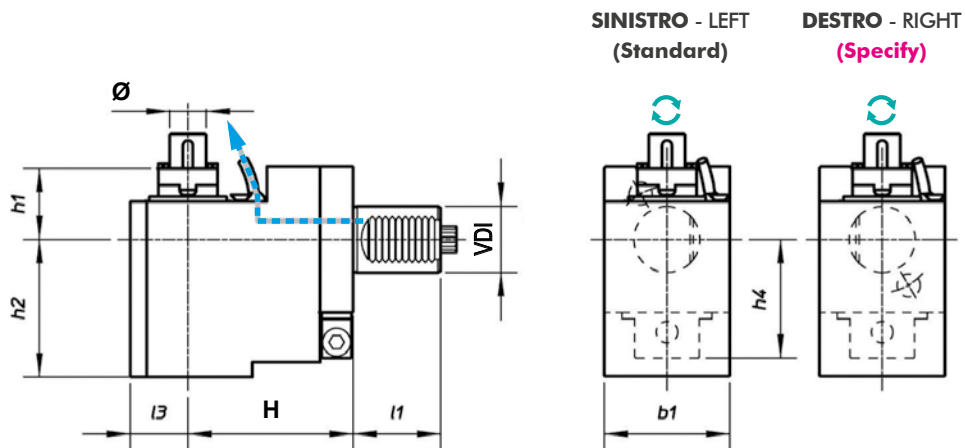
 TIPO - TYPE
Arretrato Rear Offset

 USCITA - OUTPUT
Porta Fresa Shell End Milling Cutter

 REFRIGERANTE COOLANT
Esterno External

 RATIO
1:1

 ROTAZIONE - ROTATION
Uguale al mandrino Same as machine spindle

Code	VDI	Output	Int Cool.	l1	H	l3	b1	h1	h2	h4	Nm	Rpm	kw
99.ST.8244	30	Ø22	NO	45	85	31	64	32	90	52	32	2.500	8
99.ST.8245	40	Ø22	NO	53	100	35	76	27	106	72,5	63	4.000	10

MODELLI DI TORNIO COMPATIBILI
COMPATIBLE LATHE TYPES

VDI 20 / VDI 30 / VDI 40 / VDI 50 / VDI 60



Vedi pagine compatibilità 5.10 / 5.11 - See compatibility pages 5.10 / 5.11

VDI
DIN 5482

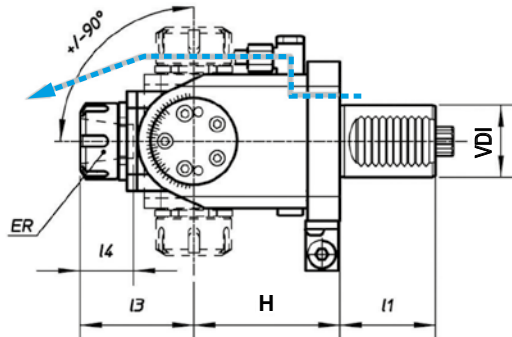
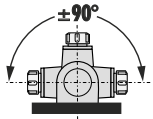

SINISTRO - LEFT
(Standard)

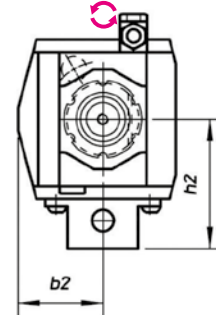

DESTRO - RIGHT
(Specify)

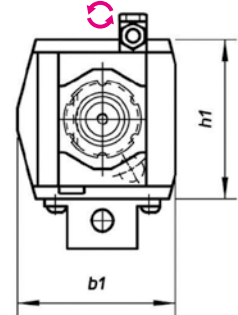

TIPO - TYPE
Orientabile
Adjustable $\pm 90^\circ$



USCITA - OUTPUT
Porta Pinza
Collet Chuck



REFRIGERANTE
COOLANT
Esterno
External



RATIO
1:1



ROTAZIONE - ROTATION
Opposto al mandrino
Opposite to machine spindle

Code	VDI	Output	Int Cool.	I1	H	I3	I4	b1	b2	h1	h2	Nm	Rpm	kw
99.ST.8248	30	ER-20 - Ø1+13	NO	45	64	52	37	70	37	64	54	15	6.000	3
99.ST.8249	30	ER-20 - Ø1+13	NO	45	97	52	37	70	37	64	54	15	6.000	3
99.ST.8250	40	ER-25 - Ø1+16	NO	53	81	63	42	87	47	88	71	25	5.000	4
99.ST.8251	50	ER-25 - Ø1+16	NO	78	100	67	47	91	54	88	72	25	4.000	6

4

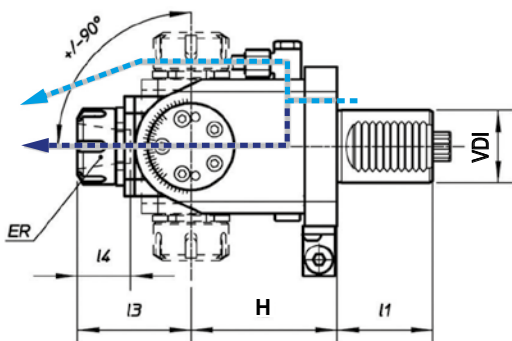
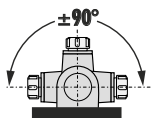

SINISTRO - LEFT
(Standard)

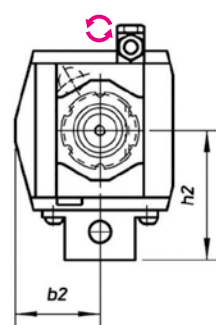

DESTRO - RIGHT
(Specify)

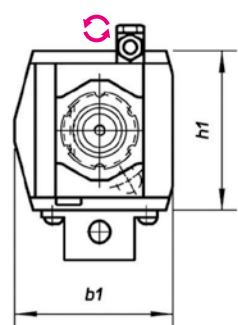

TIPO - TYPE
Orientabile
Adjustable $\pm 90^\circ$



USCITA - OUTPUT
Porta Pinza
Collet Chuck



REFRIGERANTE
COOLANT
25BAR



RATIO
1:1



ROTAZIONE - ROTATION
Opposto al mandrino
Opposite to machine spindle

Code	VDI	Output	Int Cool.	I1	H	I3	I4	b1	b2	h1	h2	Nm	Rpm	kw
99.ST.8254	30	ER-20 - Ø1+13	✓	45	97	52	37	70	37	64	54	15	6000	3
99.ST.8255	40	ER-25 - Ø1+16	✓	53	81	63	42	87	47	88	71	25	5000	4

**TORRETTA TIPO / TURRET TYPE
DIN69880 (VDI STANDARD)**



BARUFFALDI



DIN 5480

DIN 5482

DIN 1809

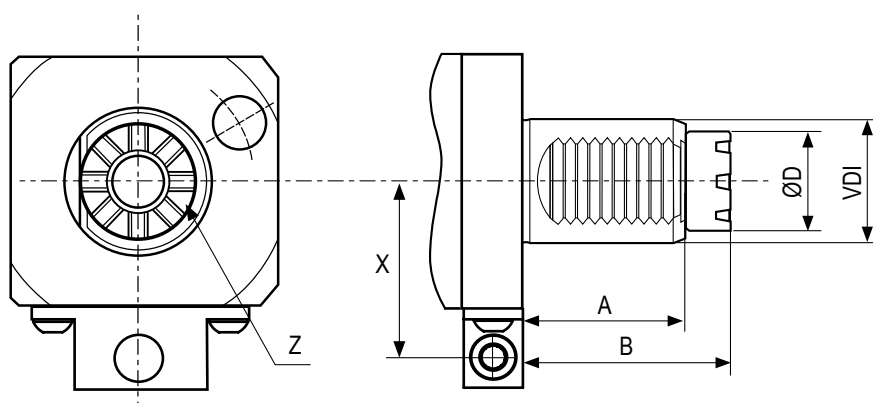

VDI	A	B	ØD	Z (N° denti - Teeth)	X
20	35	44	19	6	50
30	45	59	24	6	40
40	53	68	32	8	63
50	70	84	40	8	70
60	83	100	43	8	-



**DOTAZIONE STANDARD
STANDARD EQUIPMENT**

Chiave bloccaggio albero Art.179CH /
ugello refrigerazione Art.180 / vite bloccaggio ugello
Art.179CH shaft lock wrench /
cooling nozzle Art.180 / nozzle lock screws



CAMBI RAPIDI MODULARI Vedi pag. 7.12 - 7.15
MODULAR QUICK CHANGE See page 7.12 - 7.15

Facile e veloce sistema modulare per il cambio rapido delle diverse
tipologie di portautensili con la sede per pinza ER (DIN6499).
Modular toolholder system for the fitting of toolholders in
a spindle unit with ER collets (DIN6499) outputs.

MODELLI DI TORNIO COMPATIBILI
 COMPATIBLE LATHE TYPES

VDI 20 / VDI 30 / VDI 40 / VDI 50 / VDI 60

Vedi pagine compatibilità 5.10 / 5.11 - See compatibility pages 5.10 / 5.11

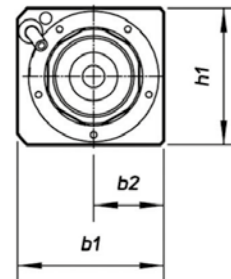
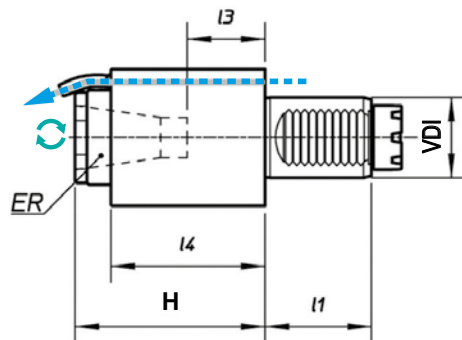
BARUFFALDI

Per dischi assiali - For axial tool discs

 TIPO - TYPE
 Assiale - Axial

 USCITA - OUTPUT
 Porta Pinza
 Collet Chuck

 REFRIGERANTE
 COOLANT
 Esterno
 External

 RATIO
1:1

 ROTAZIONE - ROTATION
 Uguale al mandrino
 Same as machine spindle

Code	VDI	Output	Int Cool.	l1	H	l3	l4	b1	b2	h1	Nm	Rpm	kw
99.BF.0001	20	ER-20 - Ø1+13	NO	35	90	49	61	50	25	56	13	6.000	5
99.BF.0002	20	ER-20 - Ø1+13	NO	35	65	25	37	50	25	56	13	6.000	5
99.BF.0003	30	ER-25 - Ø1+16	NO	45	94	39	88	62	31	64	32	6.000	8
99.BF.0005	40	ER-32 - Ø2+20	NO	53	117	57	99	73	35	70	63	5.000	10
99.BF.0007	50	ER-40 - Ø3+30	NO	70	120	45	102	88	44	88	100	4.000	12
99.BF.0009	60	ER-50 - Ø7+34	NO	83	170	69	109	110	55	110	160	3.200	15

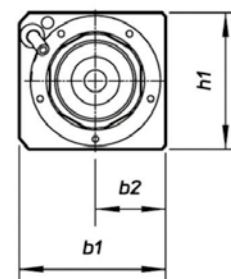
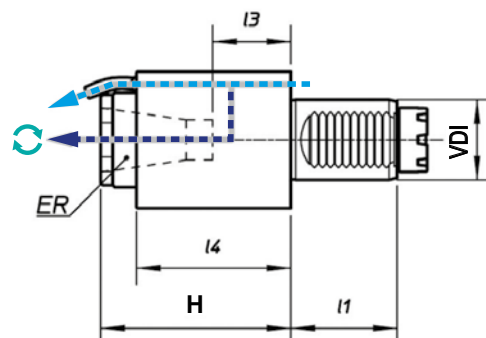
4

Per dischi assiali - For axial tool discs

 TIPO - TYPE
 Assiale - Axial

 USCITA - OUTPUT
 Porta Pinza
 Collet Chuck

 REFRIGERANTE
 COOLANT
25BAR

 RATIO
1:1

 ROTAZIONE - ROTATION
 Uguale al mandrino
 Same as machine spindle

Code	VDI	Output	Int Cool.	l1	H	l3	l4	b1	b2	h1	Nm	Rpm	kw
99.BF.0010	30	ER-25 - Ø1+16	✓	45	94	39	88	62	31	64	32	6.000	8
99.BF.0011	40	ER-32 - Ø2+20	✓	53	115	54	97	73	35	70	63	5.000	10
99.BF.0013	50	ER-40 - Ø3+30	✓	70	120	45	102	88	44	88	100	4.000	12
99.BF.0014	60	ER-50 - Ø7+34	✓	83	170	69	109	110	55	110	160	3.200	15

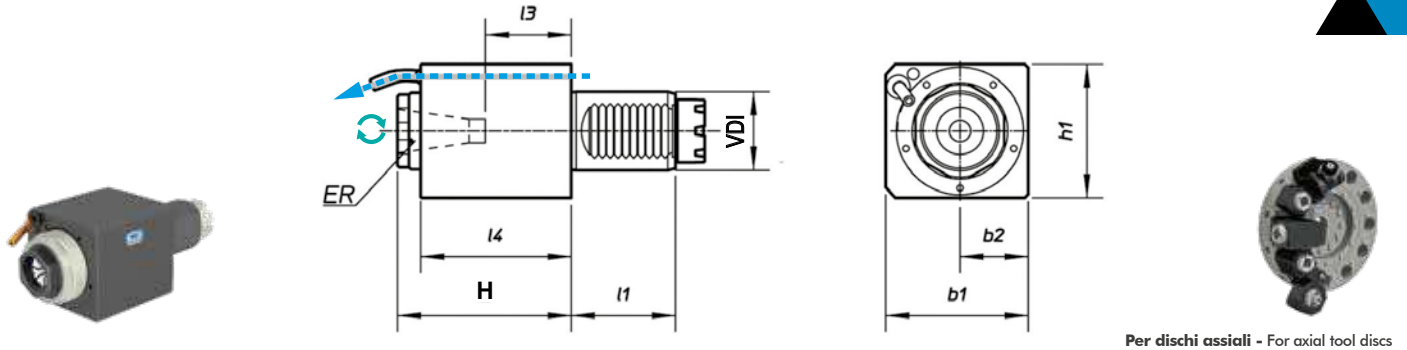

Vedi pagine compatibilità 5.10 / 5.11 - See compatibility pages 5.10 / 5.11

BARUFFALDI

Per dischi assiali - For axial tool discs

 TIPO - TYPE
Assiale - Axial

 USCITA - OUTPUT
**Porta Pinza
 Collet Chuck**

 REFRIGERANTE
 COOLANT
**Esterno
 External**

 RATIO
1:4

 ROTAZIONE - ROTATION
**Uguale al mandrino
 Same as machine spindle**

Code	VDI	Output	Int Cool.	l1	H	l3	l4	b1	b2	h1	Nm	Rpm	kw	
99.BF.0015	20	ER-16 - Ø1+10	NO	35	100	68	85	50	25	56	3	24.000	3	
99.BF.0016	30	ER-16 - Ø1+10	NO	45	100	58	88	62	31	64	8	20.000	4	
99.BF.0017	40	ER-20 - Ø1+13	NO	53	112,5	74,5	106	76	38	76	16	16.000	5	

4

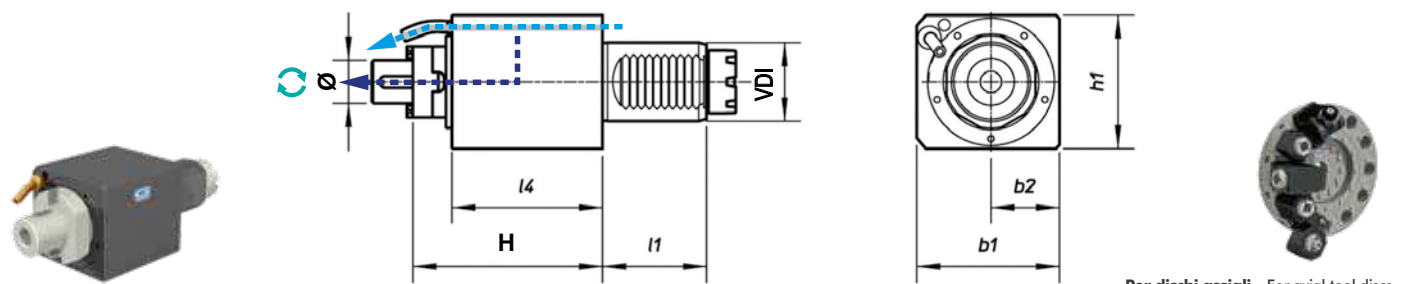

Per dischi assiali - For axial tool discs

 TIPO - TYPE
Assiale - Axial

 USCITA - OUTPUT
**Porta Fresa
 Shell End Milling Cutter**

 REFRIGERANTE
 COOLANT
25BAR

 RATIO
1:1

 ROTAZIONE - ROTATION
**Uguale al mandrino
 Same as machine spindle**

Code	VDI	Output	Int Cool.	l1	H	l4	b1	b2	h1	Nm	Rpm	kw	
99.BF.0018	30	Ø22	✓	45	112	88	62	31	64	32	5.000	8	
99.BF.0019	40	Ø22	✓	53	124	99	73	35	70	63	4.000	10	

MODELLI DI TORNIO COMPATIBILI
 COMPATIBLE LATHE TYPES

VDI 20 / VDI 30 / VDI 40 / VDI 50 / VDI 60

Vedi pagine compatibilità 5.10 / 5.11 - See compatibility pages 5.10 / 5.11



BARUFFALDI

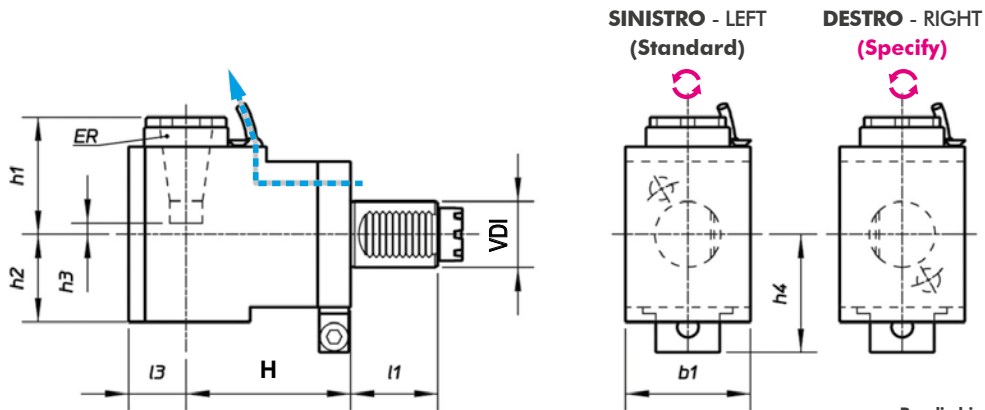

Per dischi assiali - For axial tool discs

 TIPO - TYPE
 Radiale - Radial

 USCITA - OUTPUT
 Porta Pinza
 Collet Chuck

 REFRIGERANTE
 COOLANT
 Esterno
 External

 RATIO
 1:1

 ROTAZIONE - ROTATION
 Opposto al mandrino
 Opposite to machine spindle

Code	VDI	Output	Int Cool.	l1	H	l3	b1	h1	h2	h3	h4	Nm	Rpm	kw
99.BF.0020	20	ER-20 - Ø1+13	NO	35	60	25	50	60	38	19	57	13	6.000	5
99.BF.0021	30	ER-25 - Ø1+16	NO	45	55	31	64	56	48	3	52	32	6.000	8
99.BF.0022	30	ER-25 - Ø1+16	NO	45	85	31	64	56	48	3	52	32	6.000	8
99.BF.0023	30	ER-25 - Ø1+16	NO	45	100	31	64	56	48	3	52	32	6.000	8
99.BF.0024	40	ER-32 - Ø2+20	NO	53	100	35	76	71	55	11	71	63	5.000	10
99.BF.0025	50	ER-40 - Ø3+30	NO	70	110	44	88	92	73	16	79	100	4.000	12
99.BF.0026	60	ER-50 - Ø7+34	NO	83	130	52	110	149	83	46	100	160	3.200	15

4

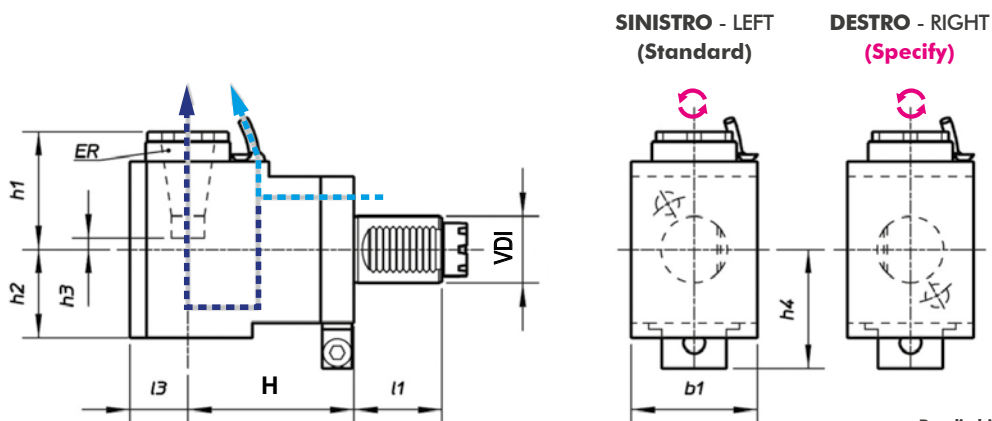

Per dischi assiali - For axial tool discs

 TIPO - TYPE
 Radiale - Radial

 USCITA - OUTPUT
 Porta Pinza
 Collet Chuck

 REFRIGERANTE
 COOLANT
 25BAR

 RATIO
 1:1

 ROTAZIONE - ROTATION
 Opposto al mandrino
 Opposite to machine spindle

Code	VDI	Output	Int Cool.	l1	H	l3	b1	h1	h2	h3	h4	Nm	Rpm	kw
99.BF.0027	30	ER-25 - Ø1+16	✓	45	55	31	64	56	60	3	52	32	6.000	8
99.BF.0028	30	ER-25 - Ø1+16	✓	45	85	31	64	56	60	3	52	32	6.000	8
99.BF.0029	30	ER-25 - Ø1+16	✓	45	100	31	64	56	60	3	52	32	6.000	8
99.BF.0030	40	ER-32 - Ø2+20	✓	53	100	35	76	71	62	11	71	63	5.000	10
99.BF.0031	50	ER-40 - Ø3+30	✓	70	110	44	88	92	73	16	79	100	4.000	12
99.BF.0032	60	ER-50 - Ø7+34	✓	83	130	52	110	149	83	46	100	160	3.200	15

MODELLI DI TORNIO COMPATIBILI
 COMPATIBLE LATHE TYPES

VDI 20 / VDI 30 / VDI 40 / VDI 50 / VDI 60

Vedi pagine compatibilità 5.10 / 5.11 - See compatibility pages 5.10 / 5.11

BARUFFALDI
SINISTRO - LEFT
 (Standard)

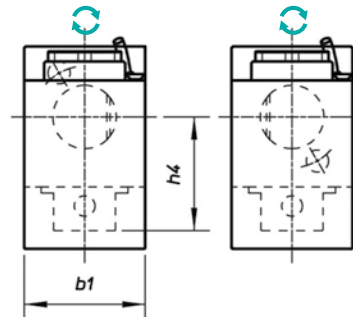
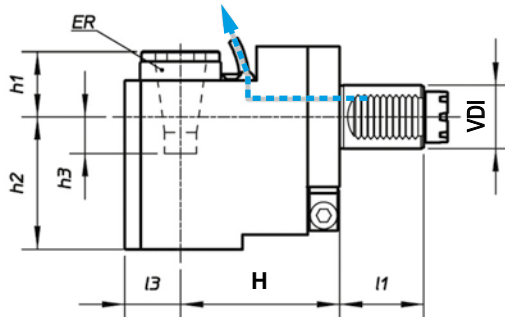
DESTRO - RIGHT
 (Specify)

Per dischi assiali - For axial tool discs

 TIPO - TYPE
Arretrato
 Rear Offset

 USCITA - OUTPUT
Porta Pinza
 Collet Chuck

 REFRIGERANTE
 COOLANT
Esterno
 External

 RATIO
1:1

 ROTAZIONE - ROTATION
Uguale al mandrino
 Same as machine spindle

Code	VDI	Output	Int Cool.	l1	H	l3	b1	h1	h2	h3	h4	Nm	Rpm	kw
99.BF.0033	20	ER-16 - Ø1+10	NO	35	75	26	50	28	48	4	56	13	6.000	5
99.BF.0034	30	ER-25 - Ø1+16	NO	45	85	31	64	14,5	90	45	52	32	5.000	8
99.BF.0035	40	ER-32 - Ø2+20	NO	53	100	35	76	20	106	40	72,5	63	4.000	10
99.BF.0036	50	ER-40 - Ø3+30	NO	70	110	44	88	31	136	46	79	100	4.000	12

4

SINISTRO - LEFT
 (Standard)

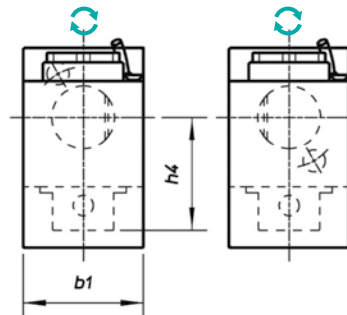
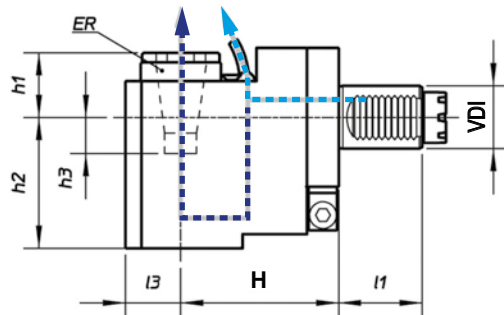
DESTRO - RIGHT
 (Specify)

Per dischi assiali - For axial tool discs

 TIPO - TYPE
Arretrato
 Rear Offset

 USCITA - OUTPUT
Porta Pinza
 Collet Chuck

 REFRIGERANTE
 COOLANT
25BAR

 RATIO
1:1

 ROTAZIONE - ROTATION
Uguale al mandrino
 Same as machine spindle

Code	VDI	Output	Int Cool.	l1	H	l3	b1	h1	h2	h3	h4	Nm	Rpm	kw
99.BF.0037	30	ER-25 - Ø1+16	✓	45	85	31	64	24	105,5	45,5	52	32	5.000	8
99.BF.0038	40	ER-32 - Ø2+20	✓	53	100	35	76	30	124	40	72,5	63	4.000	10
99.BF.0039	50	ER-40 - Ø3+30	✓	70	110	44	88	44	136	46	79	100	4.000	12

MODELLI DI TORNIO COMPATIBILI
 COMPATIBLE LATHE TYPES

VDI 20 / VDI 30 / VDI 40 / VDI 50 / VDI 60

Vedi pagine compatibilità 5.10 / 5.11 - See compatibility pages 5.10 / 5.11

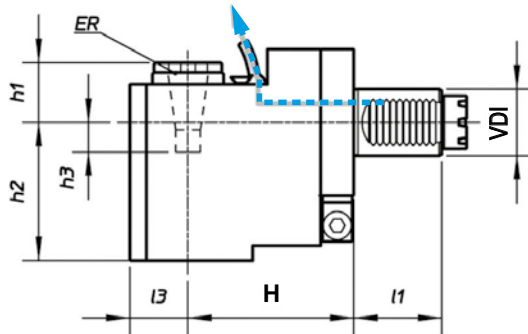
BARUFFALDI

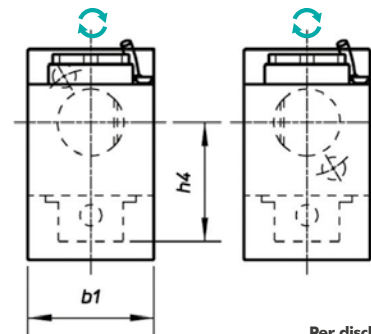
SINISTRO - LEFT
 (Standard)

DESTRO - RIGHT
 (Specify)

Per dischi assiali - For axial tool discs

 TIPO - TYPE
Arretrato
 Rear Offset

 USCITA - OUTPUT
Porta Pinza
 Collet Chuck

 REFRIGERANTE
 COOLANT
Esterno
 External

 RATIO
1:4

 ROTAZIONE - ROTATION
Uguale al mandrino
 Same as machine spindle

Code	VDI	Output	Int Cool.	l1	H	l3	b1	h1	h2	h3	h4	Nm	Rpm	kw
99.BF.0040	20	ER-25 - Ø1÷16	NO	35	75	26	50	28	48	4	56	3	24.000	3
99.BF.0041	30	ER-25 - Ø1÷16	NO	45	95	21	64	33	84	15	56	8	20.000	4
99.BF.0042	40	ER-20 - Ø1÷13	NO	53	125	27	76	45	108	10	65,5	16	16.000	5

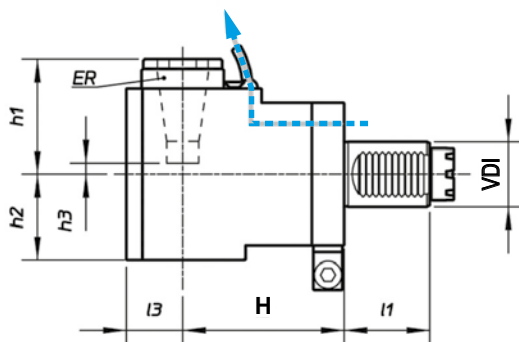
4

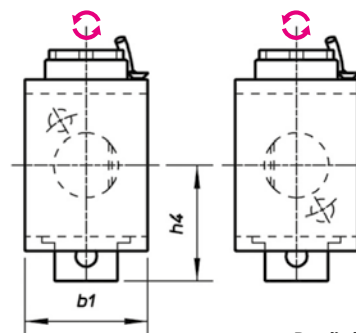
SINISTRO - LEFT
 (Standard)

DESTRO - RIGHT
 (Specify)

Per dischi assiali - For axial tool discs

 TIPO - TYPE
Radiale - Radial

 USCITA - OUTPUT
Porta Pinza
 Collet Chuck

 REFRIGERANTE
 COOLANT
Esterno
 External

 RATIO
2:1

 ROTAZIONE - ROTATION
Opposto al mandrino
 Opposite to machine spindle

Code	VDI	Output	Int Cool.	l1	H	l3	b1	h1	h2	h3	h4	Nm	Rpm	kw
99.BF.0043	30	ER-25 - Ø1÷16	NO	45	55	31	64	56,5	48	3	52	63	2.500	8
99.BF.0044	40	ER-32 - Ø2÷20	NO	53	100	35	76	71	55	-11	72,5	63	2.000	8



Vedi pagine compatibilità 5.10 / 5.11 - See compatibility pages 5.10 / 5.11

BARUFFALDI

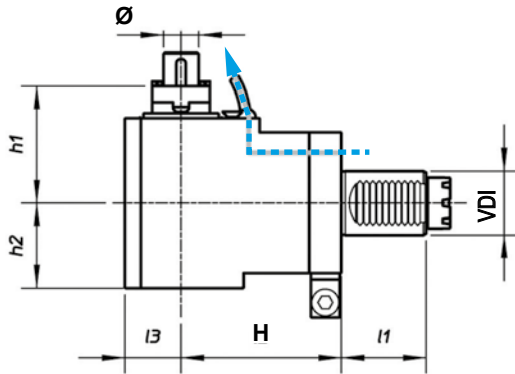
SINISTRO - LEFT
 (Standard)

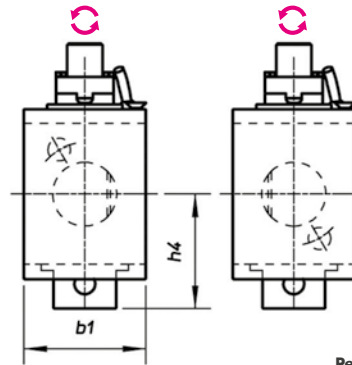
DESTRO - RIGHT
 (Specify)

Per dischi assiali - For axial tool discs

 TIPO - TYPE
 Radiale - Radial

 USCITA - OUTPUT
 Porta Fresa
 Shell End Milling Cutter

 REFRIGERANTE
 COOLANT
 Esterno
 External

 RATIO
2:1

 ROTAZIONE - ROTATION
 Opposto al mandrino
 Opposite to machine spindle

Code	VDI	Output	Int Cool.	I1	H	I3	b1	h1	h2	h4	Nm	Rpm	kw
99.BF.0045	30	Ø22	NO	45	55	31	64	74	48	52	63	2.500	8
99.BF.0046	40	Ø22	NO	53	100	35	76	78	55	72,5	63	2.000	8

4

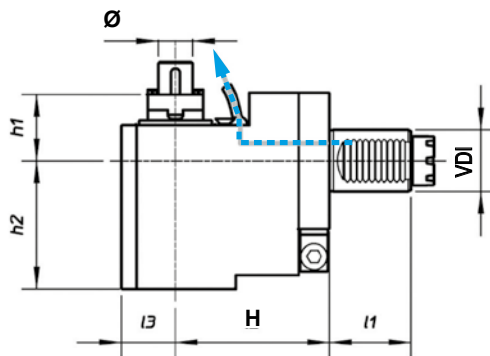
SINISTRO - LEFT
 (Standard)

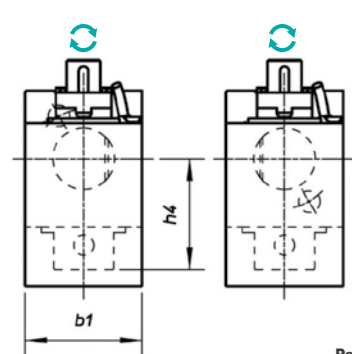
DESTRO - RIGHT
 (Specify)

Per dischi assiali - For axial tool discs

 TIPO - TYPE
 Arretrato
 Rear Offset

 USCITA - OUTPUT
 Porta Fresa
 Shell End Milling Cutter

 REFRIGERANTE
 COOLANT
 Esterno
 External

 RATIO
1:1

 ROTAZIONE - ROTATION
 Uguale al mandrino
 Same as machine spindle

Code	VDI	Output	Int Cool.	I1	H	I3	b1	h1	h2	h4	Nm	Rpm	kw
99.BF.0047	30	Ø22	NO	45	85	31	64	32	90	52	32	2500	8

MODELLI DI TORNIO COMPATIBILI
 COMPATIBLE LATHE TYPES

VDI 20 / VDI 30 / VDI 40 / VDI 50 / VDI 60

Vedi pagine compatibilità 5.10 / 5.11 - See compatibility pages 5.10 / 5.11

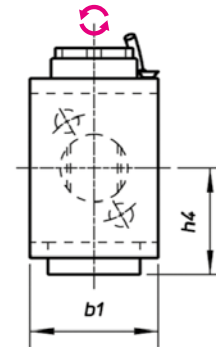
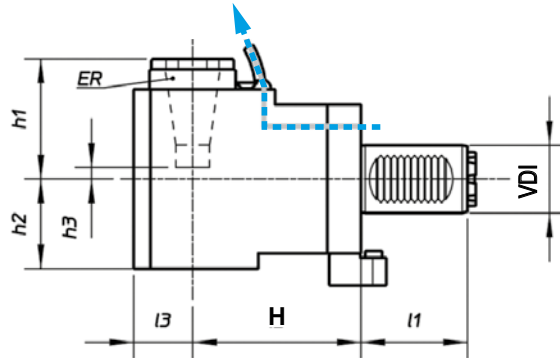
BARUFFALDI

Per dischi radiali - For radial tool discs

 TIPO - TYPE
Radiale - Radial

 USCITA - OUTPUT
**Porta Pinza
 Collet Chuck**

 REFRIGERANTE
 COOLANT
**Esterno
 External**

 RATIO
1:1

 ROTAZIONE - ROTATION
**Opposto al mandrino
 Opposite to machine spindle**

Code	VDI	Output	Int Cool.	l1	H	l3	b1	h1	h2	h3	h4	Nm	Rpm	kw
99.BF.0057	30	ER-25 - Ø1+16	NO	53	55	31	64	56	48	3	53	32	6000	8
99.BF.0058	30	ER-25 - Ø1+16	NO	53	85	31	64	56	48	3	53	32	6000	8
99.BF.0059	30	ER-25 - Ø1+16	NO	53	100	31	64	56	48	3	53	32	6000	8
99.BF.0060	50	ER-40 - Ø3+30	NO	70	110	44	88	92	73	16	68	100	4000	12

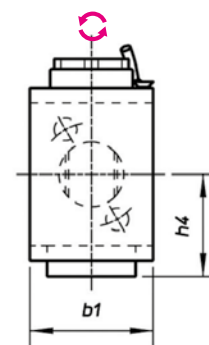
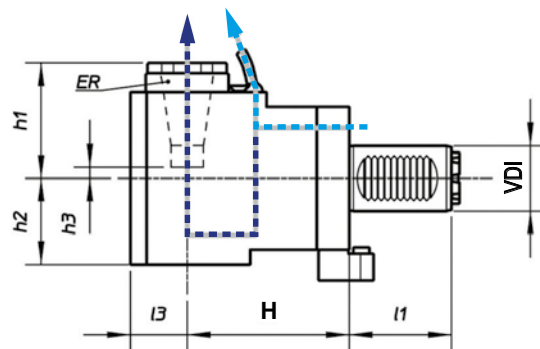
4

Per dischi radiali - For radial tool discs

 TIPO - TYPE
Radiale - Radial

 USCITA - OUTPUT
**Porta Pinza
 Collet Chuck**

 REFRIGERANTE
 COOLANT
25BAR

 RATIO
1:1

 ROTAZIONE - ROTATION
**Opposto al mandrino
 Opposite to machine spindle**

Code	VDI	Output	Int Cool.	l1	H	l3	b1	h1	h2	h3	h4	Nm	Rpm	kw
99.BF.0061	30	ER-25 - Ø1+16	✓	53	55	31	64	56	60	3	53	32	6000	8
99.BF.0062	30	ER-25 - Ø1+16	✓	53	85	31	64	56	60	3	53	32	6000	8
99.BF.0063	30	ER-25 - Ø1+16	✓	53	100	31	64	56	60	3	53	32	6000	8
99.BF.0064	50	ER-40 - Ø3+30	✓	70	110	44	88	92	62	16	68	100	4000	12

MODELLI DI TORNIO COMPATIBILI
 COMPATIBLE LATHE TYPES

VDI 20 / VDI 30 / VDI 40 / VDI 50 / VDI 60

Vedi pagine compatibilità 5.10 / 5.11 - See compatibility pages 5.10 / 5.11

BARUFFALDI

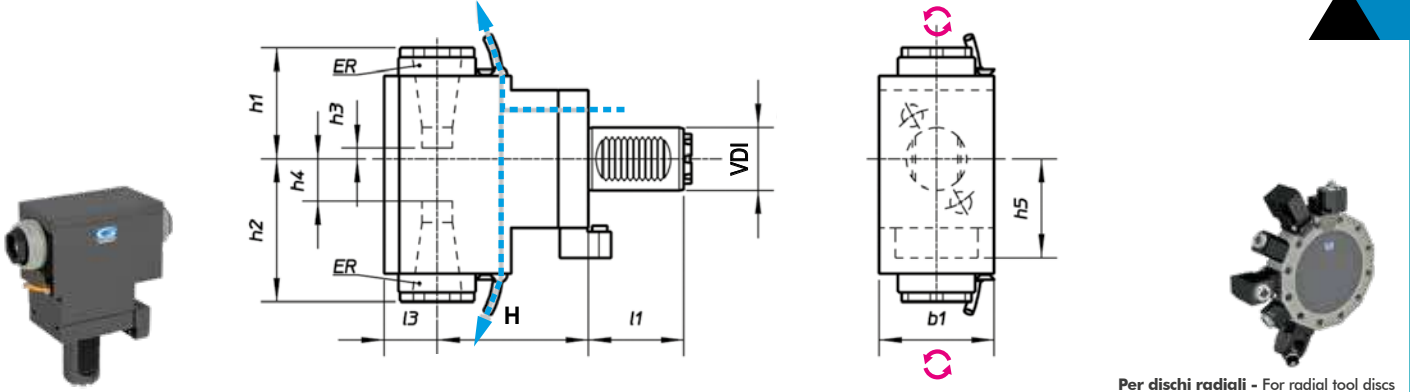

Per dischi radiali - For radial tool discs

 TIPO - TYPE
Radiale Doppio
 Double Radial

 USCITA - OUTPUT
Porta Pinza
 Collet Chuck

 REFRIGERANTE
 COOLANT
Esterno
 External

 RATIO
1:1

 ROTAZIONE - ROTATION
Opposto al mandrino
 Opposite to machine spindle

Code	VDI	Output	Int Cool.	l1	H	l3	b1	h1	h2	h3	h4	h5	Nm	Rpm	kw
99.BF.0067	30	ER-25 - Ø1+16	NO	53	110	31	64	56	68	7	23	53	32	6000	8
99.BF.0068	50	ER-40 - Ø3+30	NO	70	140	44	88	93	106	39	52	68	100	4000	12

MODELLI DI TORNIO COMPATIBILI
 COMPATIBLE LATHE TYPES

VDI 20 / VDI 30 / VDI 40 / VDI 50 / VDI 60

Vedi pagine compatibilità 5.10 / 5.11 - See compatibility pages 5.10 / 5.11

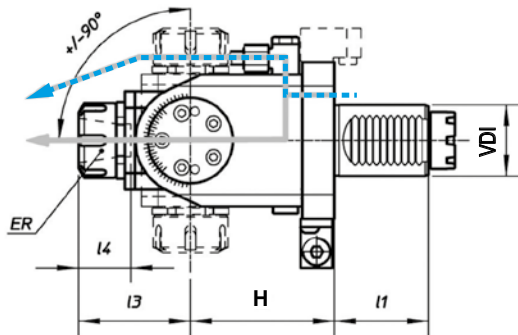
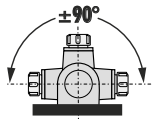
SINISTRO - LEFT
 (Standard)

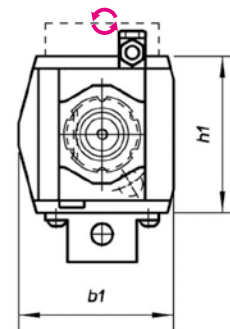
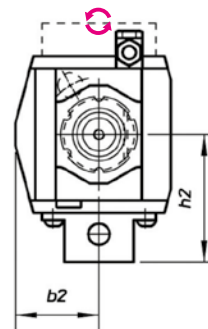
DESTRO - RIGHT
 (Specify)

 TIPO - TYPE
Orientabile
 Adjustable $\pm 90^\circ$

 USCITA - OUTPUT
Porta Pinza
 Collet Chuck

 REFRIGERANTE
 COOLANT
Esterno
 External

 RATIO
1:1

 ROTAZIONE - ROTATION
Opposto al mandrino
 Opposite to machine spindle

Code	VDI	Output	Int Cool.	l1	H	l3	l4	b1	b2	h1	h2	Nm	Rpm	kw
99.BF.0051	30	ER-20 - Ø1+13	NO	45	64	52	37	70	37	64	54	15	6000	3
99.BF.0052	30	ER-20 - Ø1+13	NO	45	97	52	37	70	37	64	54	15	6000	3
99.BF.0053	40	ER-25 - Ø1+16	NO	53	81	63	42	87	47	88	71	25	5000	4

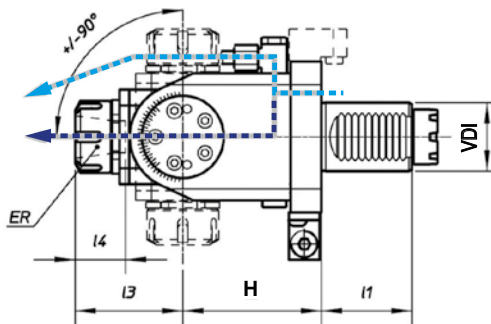
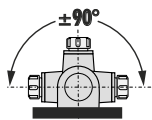
SINISTRO - LEFT
 (Standard)

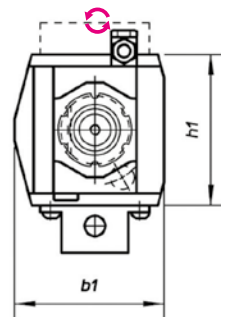
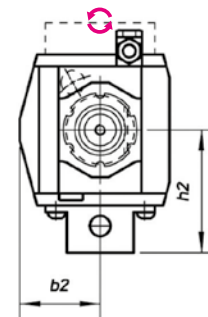
DESTRO - RIGHT
 (Specify)

 TIPO - TYPE
Orientabile
 Adjustable $\pm 90^\circ$

 USCITA - OUTPUT
Porta Pinza
 Collet Chuck

 REFRIGERANTE
 COOLANT
25BAR

 RATIO
1:1

 ROTAZIONE - ROTATION
Opposto al mandrino
 Opposite to machine spindle

Code	VDI	Output	Int Cool.	l1	H	l3	l4	b1	b2	h1	h2	Nm	Rpm	kw
99.BF.0054	30	ER-20 - Ø1+13	✓	45	64	52	37	70	37	64	54	15	6000	3
99.BF.0055	30	ER-20 - Ø1+13	✓	45	97	52	37	70	37	64	54	15	6000	3
99.BF.0056	40	ER-25 - Ø1+16	✓	53	81	63	42	87	47	88	71	25	5000	4

TORRETTA TIPO / TURRET TYPE
DIN69880 (VDI STANDARD)



DIN 1809



DIN 5480

DIN 5482

BARUFFALDI

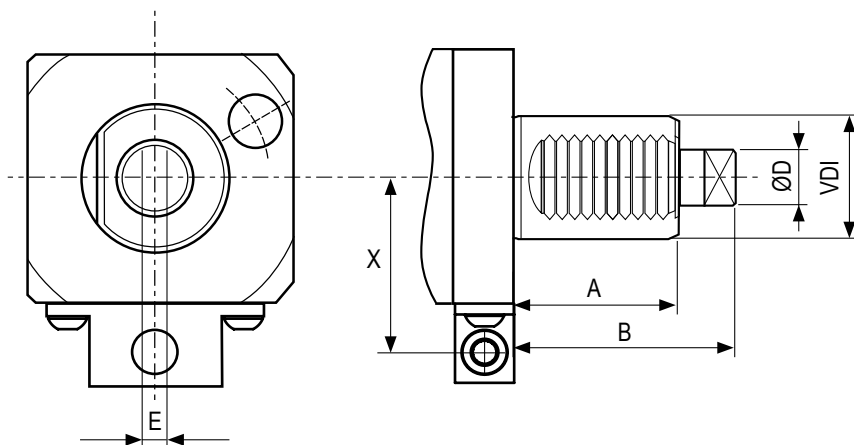

VDI	A	B	ØD	E	X
20	35	48	10	5	40
30	45	62	12	6	40
40	53	72	18	8	63
50	78	92	24	13	63
60	83	110	29	14	-



DOTAZIONE STANDARD
STANDARD EQUIPMENT

Chiave bloccaggio albero Art.179CH /
ugello refrigerazione Art.180 / vite bloccaggio ugello
Art.179CH shaft lock wrench /
cooling nozzle Art.180 / nozzle lock screws



CAMBI RAPIDI MODULARI Vedi pag. 7.12 - 7.15
MODULAR QUICK CHANGE See page 7.12 - 7.15

Facile e veloce sistema modulare per il cambio rapido delle diverse
tipologie di portautensili con la sede per pinza ER (DIN6499).
Modular toolholder system for the fitting of toolholders in
a spindle unit with ER collets (DIN6499) outputs.

MODELLI DI TORNIO COMPATIBILI
COMPATIBLE LATHE TYPES

VDI 20 / VDI 25 / VDI 30 / VDI 50 / VDI 60



Vedi pagine compatibilità 5.10 / 5.11 - See compatibility pages 5.10 / 5.11

VDI
DIN 1809

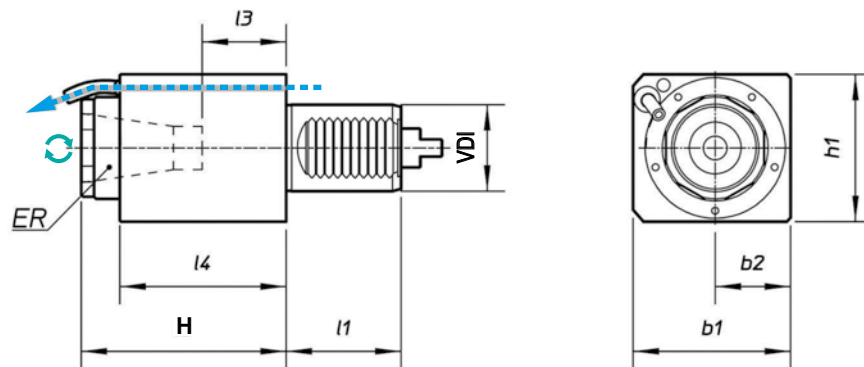

TIPO - TYPE
Assiale - Axial



USCITA - OUTPUT
Porta Pinza
Collet Chuck



REFRIGERANTE
COOLANT
Esterno
External



RATIO
1:1
1:4



ROTAZIONE - ROTATION
Uguale al mandrino
Same as machine spindle

Code	VDI	Output	Int Cool.	l1	H	l3	l4	b1	b2	h1	Nm	Rpm	kw
99.DP.0901	20	ER-20 - Ø1÷13	NO	35	65	25	37	50	25	56	13	6000	5
99.DP.0902	20	ER-20 - Ø1÷13	NO	35	90	49	61	50	25	56	13	6000	5
99.DP.0903	30	ER-25 - Ø1÷16	NO	45	94	39	88	62	31	64	32	6000	8
99.DP.0904	30	ER-25 - Ø1÷16	NO	45	66	21	59	62	31	64	32	6000	8
99.DP.0905	40	ER-32 - Ø2÷20	NO	53	115	54	97	73	35	70	63	5000	10
99.DP.0907	50	ER-40 - Ø3÷30	NO	70	120	45	102	88	44	88	100	4000	12
99.DP.0908	50	ER-40 - Ø3÷30	NO	70	88	69	25	88	44	88	100	4000	12
99.DP.0909	60	ER-50 - Ø7÷34	NO	83	170	69	109	110	55	110	160	3200	15
99.DP.0915	20	ER-16 - Ø1÷10	NO	35	100	68	85	50	25	56	3	24000	3
99.DP.0916	30	ER-16 - Ø1÷10	NO	45	100	58	88	62	31	64	8	20000	4

4

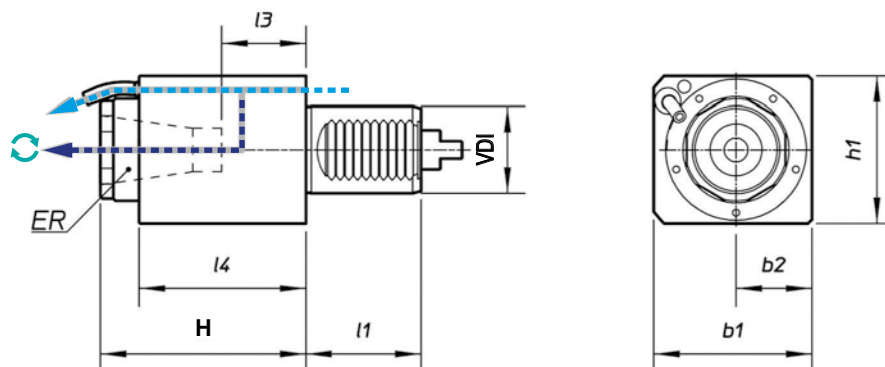

TIPO - TYPE
Assiale - Axial



USCITA - OUTPUT
Porta Pinza
Collet Chuck



REFRIGERANTE
COOLANT
25BAR



RATIO
1:1



ROTAZIONE - ROTATION
Uguale al mandrino
Same as machine spindle

Code	VDI	Output	Int Cool.	l1	H	l3	l4	b1	b2	h1	Nm	Rpm	kw
99.DP.0910	30	ER-25 - Ø1÷16	✓	45	94	39	88	62	31	64	32	6000	8
99.DP.0911	40	ER-32 - Ø2÷20	✓	53	115	54	97	73	35	70	63	5000	10
99.DP.0913	50	ER-40 - Ø3÷30	✓	70	120	45	102	88	44	88	100	4000	12
99.DP.0914	60	ER-50 - Ø7÷34	✓	83	170	69	109	110	55	110	160	3200	15

MODELLI DI TORNIO COMPATIBILI
 COMPATIBLE LATHE TYPES

VDI 20 / VDI 25 / VDI 30 / VDI 50 / VDI 60

Vedi pagine compatibilità 5.10 / 5.11 - See compatibility pages 5.10 / 5.11

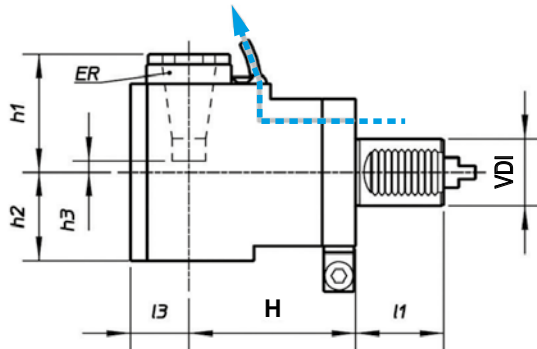
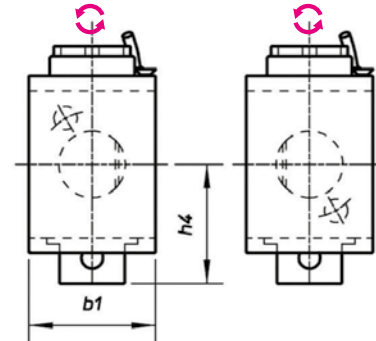
VDI
DIN 1809

SINISTRO - LEFT
(Standard)
DESTRO - RIGHT
(Specify)

 TIPO - TYPE
Radiale - Radial

 USCITA - OUTPUT
**Porta Pinza
 Collet Chuck**

 REFRIGERANTE
 COOLANT
**Esterno
 External**

 RATIO
1:1

 ROTAZIONE - ROTATION
**Opposto al mandrino
 Opposite to machine spindle**

Code	VDI	Output	Int Cool.	l1	H	l3	b1	h1	h2	h3	h4	Nm	Rpm	kw
99.DP.0918	20	ER-20 - Ø1+13	NO	35	60	25	50	60	38	19	57	13	6000	5
99.DP.0919	30	ER-25 - Ø1+16	NO	45	55	31	64	56	48	3	52	32	6000	8
99.DP.0920	30	ER-25 - Ø1+16	NO	45	85	31	64	56	48	3	52	32	6000	8
99.DP.0921	30	ER-25 - Ø1+16	NO	45	100	31	64	56	48	3	52	32	6000	8
99.DP.0922	40	ER-32 - Ø2+20	NO	53	100	35	76	71	55	11	71	63	6000	10
99.DP.0923	50	ER-40 - Ø3+30	NO	70	110	44	88	92	73	16	79	100	4000	12
99.DP.0924	60	ER-50 - Ø7+34	NO	83	130	52	110	149	83	46	100	160	3200	15

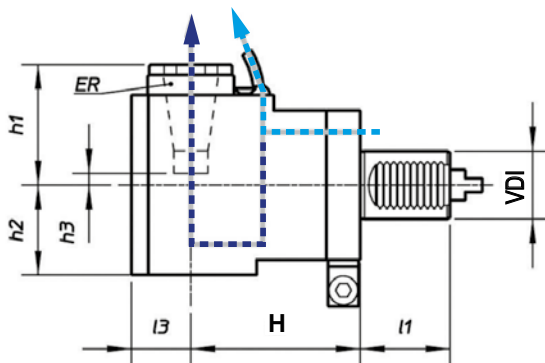
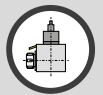
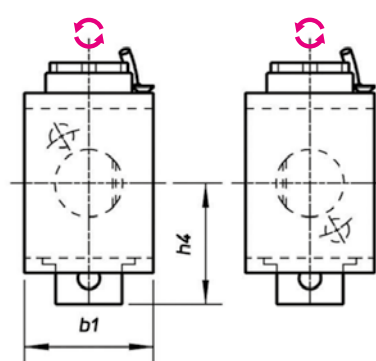
SINISTRO - LEFT
(Standard)
DESTRO - RIGHT
(Specify)

 TIPO - TYPE
Radiale - Radial

 USCITA - OUTPUT
**Porta Pinza
 Collet Chuck**

 REFRIGERANTE
 COOLANT
25BAR

 RATIO
1:1

 ROTAZIONE - ROTATION
**Opposto al mandrino
 Opposite to machine spindle**

Code	VDI	Output	Int Cool.	l1	H	l3	b1	h1	h2	h3	h4	Nm	Rpm	kw
99.DP.0925	30	ER-25 - Ø1+16	✓	45	55	31	64	56	60	3	52	32	6000	8
99.DP.0926	30	ER-25 - Ø1+16	✓	45	85	31	64	56	60	3	52	32	6000	8
99.DP.0927	30	ER-25 - Ø1+16	✓	45	100	31	64	56	60	3	52	32	6000	8
99.DP.0928	40	ER-32 - Ø2+20	✓	53	100	35	76	71	62	11	71	63	5000	10
99.DP.0929	50	ER-40 - Ø3+30	✓	70	110	44	88	92	73	16	79	100	4000	12
99.DP.0930	60	ER-50 - Ø7+34	✓	83	130	52	110	149	83	46	100	160	3200	15

MODELLI DI TORNIO COMPATIBILI
COMPATIBLE LATHE TYPES

VDI 20 / VDI 25 / VDI 30 / VDI 50 / VDI 60



Vedi pagine compatibilità 5.10 / 5.11 - See compatibility pages 5.10 / 5.11

VDI
DIN 1809

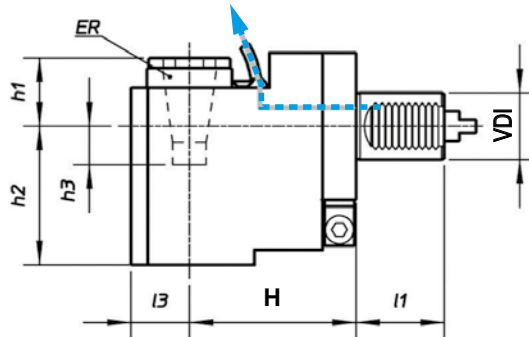

SINISTRO - LEFT
(Standard)

DESTRO - RIGHT
(Specify)

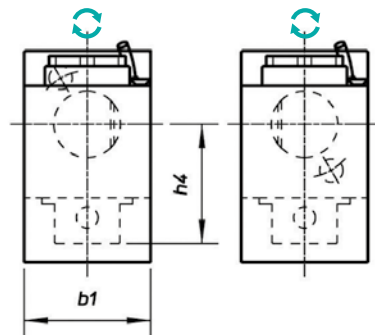

TIPO - TYPE
Arretrato
Rear Offset



USCITA - OUTPUT
Porta Pinza
Collet Chuck



REFRIGERANTE
COOLANT
Esterno
External



RATIO
1:1



ROTAZIONE - ROTATION
Ugualo al mandrino
Same as machine spindle

Code	VDI	Output	Int Cool.	l1	H	l3	b1	h1	h2	h3	h4	Nm	Rpm	kw
99.DP.0931	20	ER-16 - Ø1+10	NO	35	75	26	50	28	48	4	56	13	6.000	5
99.DP.0932	30	ER-25 - Ø1+16	NO	45	85	31	64	14,5	90	45	52	32	5.000	8
99.DP.0933	40	ER-32 - Ø2+20	NO	53	100	35	76	20	106	40	72,5	63	4.000	10
99.DP.0934	50	ER-40 - Ø3+30	NO	70	110	44	88	31	136	46	79	100	4.000	12

4

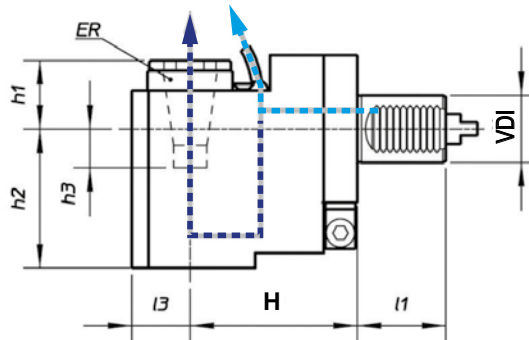

SINISTRO - LEFT
(Standard)

DESTRO - RIGHT
(Specify)

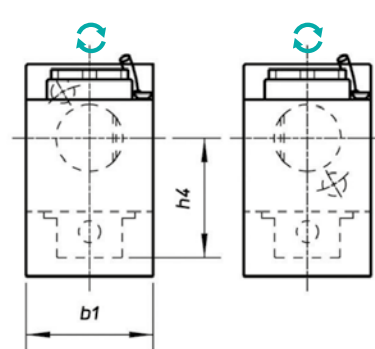

TIPO - TYPE
Arretrato
Rear Offset



USCITA - OUTPUT
Porta Pinza
Collet Chuck



REFRIGERANTE
COOLANT
25BAR



RATIO
1:1



ROTAZIONE - ROTATION
Ugualo al mandrino
Same as machine spindle

Code	VDI	Output	Int Cool.	H	l2	l3	b1	h1	h2	h3	h4	Nm	Rpm	kw
99.DP.0935	30	ER-25 - Ø1+16	✓	85	45	31	64	24	105,5	45,5	52	32	5.000	8
99.DP.0936	40	ER-32 - Ø2+20	✓	100	53	35	76	30	124	40	72,5	63	4.000	10
99.DP.0937	50	ER-40 - Ø3+30	✓	110	70	44	88	44	136	46	79	100	4.000	12

MODELLI DI TORNIO COMPATIBILI
COMPATIBLE LATHE TYPES

VDI 20 / VDI 25 / VDI 30 / VDI 50 / VDI 60



Vedi pagine compatibilità 5.10 / 5.11 - See compatibility pages 5.10 / 5.11

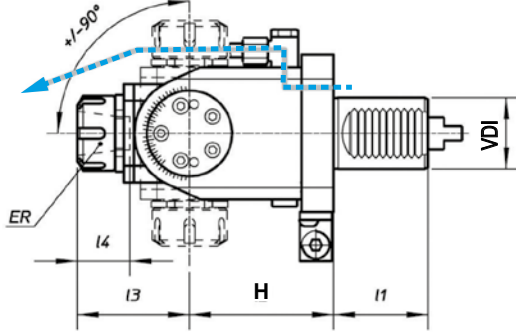
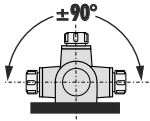

SINISTRO - LEFT
(Standard)

DESTRO - RIGHT
(Specify)

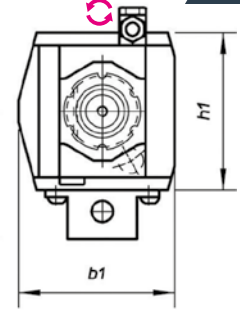
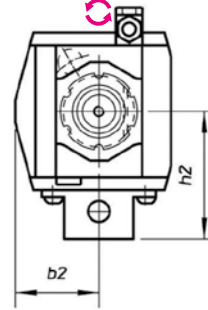

VDI
DIN 1809



TIPO - TYPE
Orientabile
Adjustable $\pm 90^\circ$



USCITA - OUTPUT
Porta Pinza
Collet Chuck



REFRIGERANTE
COOLANT
Esterno
External



RATIO
1:1



ROTAZIONE - ROTATION
Opposto al mandrino
Opposite to machine spindle

Code	VDI	Output	Int Cool.	I1	H	I3	I4	b1	b2	h1	h2	Nm	Rpm	kw
99.DP.0940	30	ER-20 - Ø1+13	NO	45	64	52	37	70	37	64	54	15	6.000	3
99.DP.0941	30	ER-20 - Ø1+13	NO	45	97	52	37	70	37	64	54	15	6.000	3
99.DP.0942	40	ER-25 - Ø1+16	NO	53	81	63	42	87	47	88	71	25	5.000	4

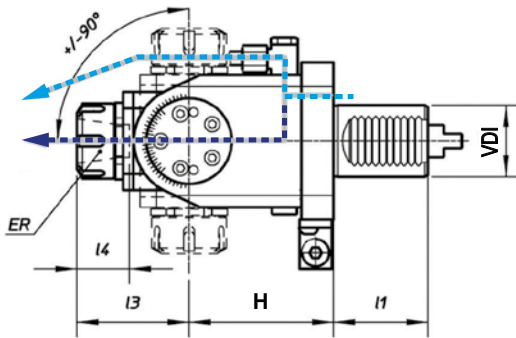
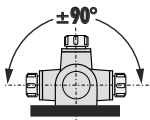

SINISTRO - LEFT
(Standard)

DESTRO - RIGHT
(Specify)

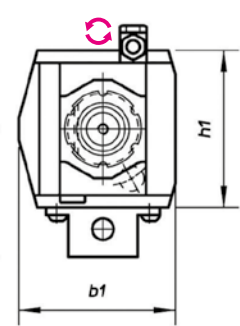
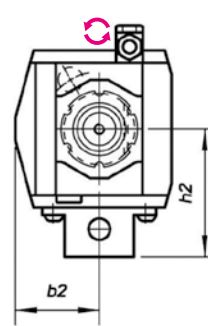

TIPO - TYPE
Orientabile
Adjustable $\pm 90^\circ$



USCITA - OUTPUT
Porta Pinza
Collet Chuck



REFRIGERANTE
COOLANT
25BAR



RATIO
1:1



ROTAZIONE - ROTATION
Opposto al mandrino
Opposite to machine spindle

Code	VDI	Output	Int Cool.	I1	H	I3	I4	b1	b2	h1	h2	Nm	Rpm	kw
99.DP.0943	30	ER-20 - Ø1+13	✓	45	64	52	37	70	37	64	54	15	6.000	3
99.DP.0944	30	ER-20 - Ø1+13	✓	45	97	52	37	70	37	64	54	15	6.000	3
99.DP.0945	40	ER-25 - Ø1+16	✓	53	81	63	42	87	47	88	71	25	5.000	4

PIÙ SEMPLICE / PIÙ INFO / PIÙ PRODOTTI - EASIER / MORE INFO / MORE PRODUCTS

TROVA IL TUO PRODOTTO IN POCHI CLICK - FIND YOUR PRODUCT IN FEW CLICKS



by category



by code



by description



by configurator

Un nuovo modo facile e veloce per ordinare la tua attrezzatura Gerardi

Il nuovo Gerardi estore offre la possibilità di visualizzare e ordinare qualsiasi articolo Gerardi appartenente alle categorie Workholding o Tooling presente sui nostri listini in modo semplice, veloce e completo. Da ora puoi ordinare la morsa, la testa angolare o il motorizzato che ti interessa direttamente on-line dal nostro estore senza costi aggiuntivi.

A new quick and easy way to order your equipment branded Gerardi.

The new Gerardi estore offers the ability to view and order any item available on our Workholding and Tooling catalogues with the easiest, fastest and comprehensive way. You can now order the vise, angle head or driven tool of your interest directly online from our store without any additional cost.



WINDOWS / IOS



ANDROID / IPHONE

