

P145/P190系列面铣刀 P145/P190 series face milling cutter

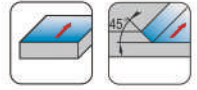

Kr:45°

Kr:88°

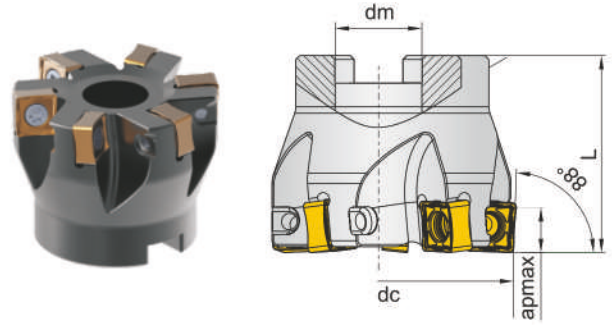
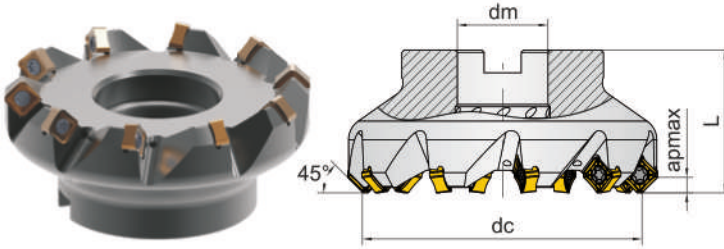

B

型号 Type	库存状态 Stock	尺寸 (mm) Dimension						齿数 Teeth Z	内冷状态 Cooling	重量 kg
		dc	dm	apmax	L					
P145-50Z04SN12-A22	○	50	22	6.5	40			4	+	0.40
P145-63Z06SN12-A22	●	63	22	6.5	40			6	+	0.60
P145-80Z07SN12-A27	●	80	27	6.5	50			7	+	1.40
P145-100Z08SN12-A32	●	100	32	6.5	50			8	+	1.90
P145-125Z10SN12-A40	●	125	40	6.5	63			10	+	3.20
P145-160Z12SN12-B40	●	160	40	6.5	63			12		5.90
P145-200Z18SN12-B60	○	200	60	6.5	63			18		9.10
P190-63Z05SN12-A22	●	63	22	10	50			5		0.60
P190-80Z06SN12-A27	●	80	27	10	50			6		1.40
P190-100Z08SN12-A32	●	100	32	10	50			8		1.90
P190-125Z10SN12-A40	○	125	40	10	63			10		3.20
P190-160Z12SN12-B40	○	160	40	10	63			12		4.39

● 常备库存 regular stock ○ 按订单生产 order for manufacturing



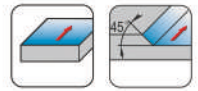

P145系列面铣刀刀片
P145 series face milling insert

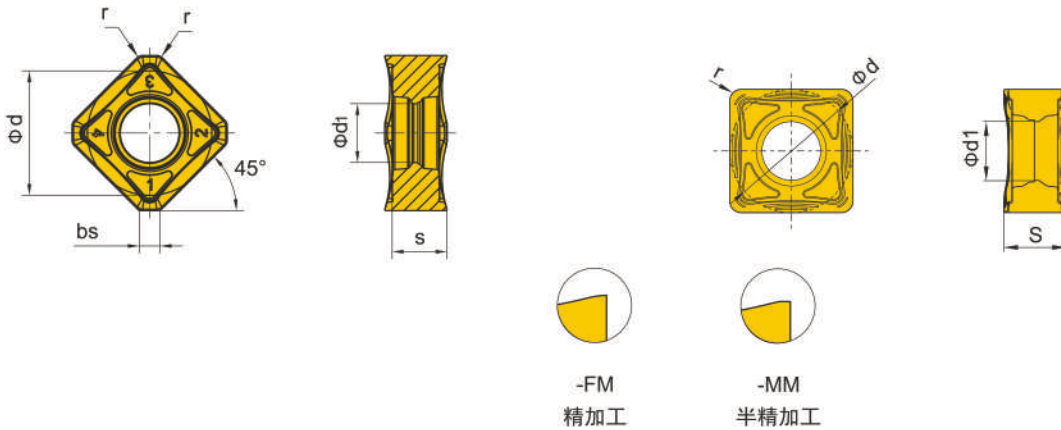

B

加工状态 Working Condition:

● 稳定切削 Steady Cutting ● 一般切削 General Cutting ○ 不稳定切削 Unsteady Cutting

●	●	●	●	●	●	●	●	●	●	●	●	●
○	○	○	○	○	○	○	○	○	○	○	○	○

型号 Type	基本尺寸 (mm) Dimension					P		M		K		S		N		
	d	s	d1	r	bs	PP2125	PX6140	PP2125	PX6140	PX5110	PP2125	PX6140	PP4115	PX6140	PH3110	PH3120
SNMX1205ANEN-FM	12.7	5.56	6	0.8	1.5	☆	★	★	☆	☆	☆	★				
SNMX120512-MM	12.7	5.56	6	1.2		☆	★	★	☆	☆	☆	★				

★ 为第一推荐牌号 Recommended Grade
☆ 为第二推荐牌号 Optional Grade

配件/SPARE PARTS

安装形式 Type of clamping	刀具直径(mm) Diameter (mm)	螺钉 Screw 	扳手 Wrench
A	D50-D125	S050L12S	WT-20T
B	D160-D200	S050L12S	WT-20T

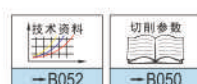

P145系列面铣刀
P145 series face milling cutter

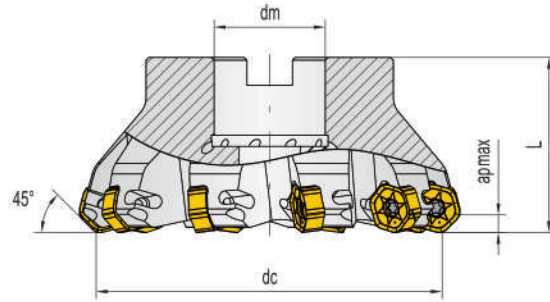
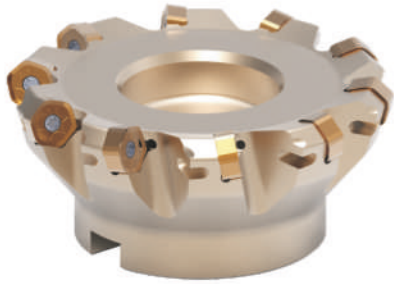
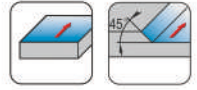

B

型号 Type	库存状态 Stock	尺寸 (mm) Dimension								齿数 Teeth Z	内冷状态 Cooling	重量 kg
		dc	dm	apmax	L							
P145-50Z04HN09-A22	○	50	22	5	40					4	+	0.35
P145-63Z06HN09-A22	○	63	22	5	40					6	+	0.49
P145-80Z06HN09-A27	○	80	27	5	50					6	+	1.06
P145-100Z08HN09-A32	○	100	32	5	50					8	+	1.74
P145-125Z10HN09-A40	○	125	40	5	63					10	+	3.24
P145-160Z12HN09-B40	○	160	40	5	63					12		5.70
P145-200Z10HN09-B60	○	200	60	5	63					10		9.00
P145-250Z14HN09-B60	○	250	60	5	63					14		12.80
P145-315Z16HN09-D60	○	315	60	5	80					16		32.20

● 常备库存 regular stock ○ 按订单生产 order for manufacturing



P145系列面铣刀刀片 P145 series face milling insert

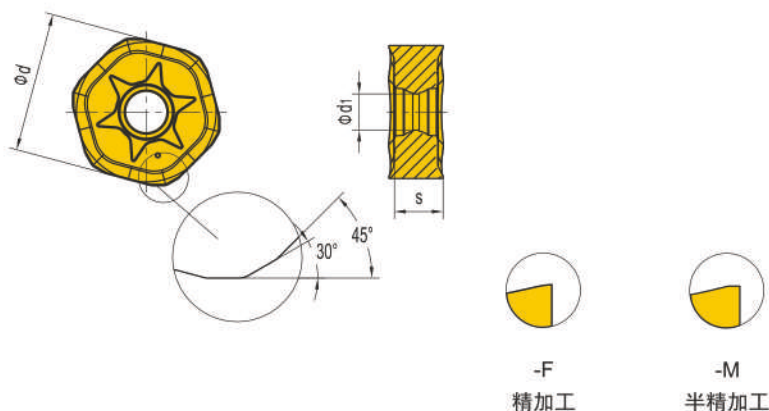
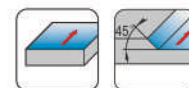

B

加工状态 Working Condition:

- 稳定切削 Steady Cutting
- ◐ 一般切削 General Cutting
- 不稳定切削 Unsteady Cutting

●				●	●							
◐	◐	◐						◐				
		○		○		○						

型号 Type	基本尺寸 (mm) Dimension				P		M		K		S		N		
	d	s	d1		PP2125	PX6140	PP2125	PX6140	PX5110	PP2125	PX6140	PP4115	PX6140	PH3110	PH3120
HNGX0906ANSN-F	16.5	6.35	4.9		☆	★	★	☆	☆	☆	★				
HNGX0906ANSN-M	16.5	6.35	4.9		☆	★	★	☆	☆	☆	★				

★ 为第一推荐牌号 Recommended Grade
☆ 为第二推荐牌号 Optional Grade

配件/SPARE PARTS

安装形式 Type of clamping	刀具直径(mm) Diameter (mm)	螺钉 Screw	扳手 Wrench
A	D50-D125	S045L12T	WT20-T
B	D160-D250	S045L12T	WT20-T
D	D315	S045L12T	WT20-T

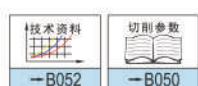

P110系列大进给铣刀 P110 series high feed milling cutter

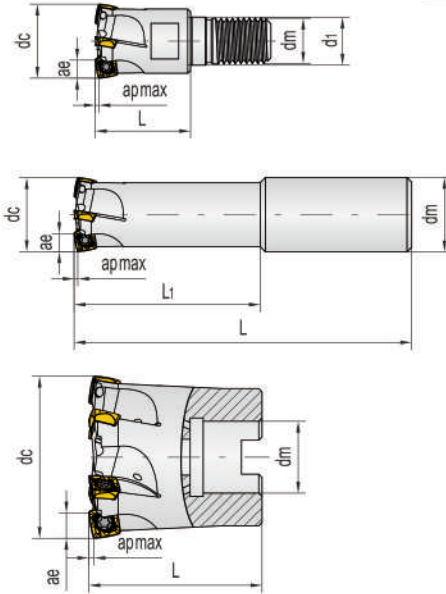

B

型号 Type	库存状态 Stock	尺寸 (mm) Dimension								齿数 Teeth Z	内冷状态 Cooling	重量 kg
		dc	dm	apmax	ae	L	d1	L1				
P110-22Z02SD09-M10	●	22	M10	1.5	9	30	10.5			2	+	0.10
P110-25Z03SD09-M12	●	25	M12	1.5	9	35	12.5			3	+	0.14
P110-30Z04SD09-M16	●	30	M16	1.5	9	42	17			4	+	0.20
P110-32Z04SD09-M16	●	32	M16	1.5	9	42	17			4	+	0.23
P110-40Z05SD09-M16	●	40	M16	1.5	9	42	17			5	+	0.30
P110-22Z02SD09-C20	●	22	20	1.5	9	140		65		2	+	0.35
P110-25Z03SD09-C25	●	25	25	1.5	9	145		80		3	+	0.50
P110-30Z04SD09-C25	●	30	25	1.5	9	145		80		4	+	0.75
P110-32Z04SD09-C32	●	32	32	1.5	9	145		80		4	+	0.80
P110-40Z05SD09-C32	●	40	32	1.5	9	145		80		5	+	1.30
P110-40Z05SD09-A16	●	40	16	1.5	9	35				5	+	0.20
P110-50Z06SD09-A22	●	50	22	1.5	9	40				6	+	0.30
P110-63Z08SD09-A22	●	63	22	1.5	9	50				8	+	0.49
P110-63Z05SD13-A22	○	63	22	2.5	13	40				5	+	0.36
P110-63Z06SD13-A22	○	63	22	2.5	13	40				6	+	0.38
P110-80Z06SD13-A27	○	80	27	2.5	13	50				6	+	0.93
P110-80Z07SD13-A27	○	80	27	2.5	13	50				7	+	1.20

● 常备库存 regular stock ○ 按订单生产 order for manufacturing



P110系列大进给铣刀刀片
P110 series high feed milling insert

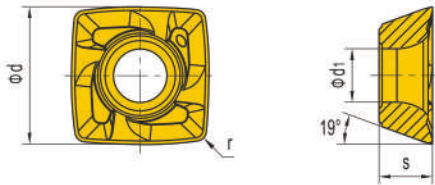
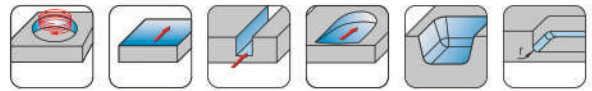

面铣和仿形加工



B

加工状态 Working Condition:		● 稳定切削 Steady Cutting		● 一般切削 General Cutting		○ 不稳定切削 Unsteady Cutting									
		●	●	●	●	○	○	○	○	○	○	○	○	○	○
型号 Type	基本尺寸 (mm) Dimension				P		M		K		S		N		
	d	s	d1	r	PP2125	PX6140	PP2125	PX6140	PX5110	PP2125	PX6140	PP4115	PX6140	PH3110	PH3120
SDMT090307-SF	9	3.5	3.5	0.7	☆		☆			☆		★			
SDMT090307-SM	9	3.5	3.5	0.7	☆		☆			☆		★			
SDMT130512-SF	13	5	5	1.2	☆		☆			☆		★			
SDMT130512-SM	13	5	5	1.2	☆		☆			☆		★			

★ 为第一推荐牌号 Recommended Grade
☆ 为第二推荐牌号 Optional Grade

配件/SPARE PARTS

安装形式 Type of clamping	刀具直径(mm) Diameter (mm)	螺钉 Screw	扳手 Wrench
M	D22-D40	S030L08S	WT-T08
C	D22-D40	S030L08S	WT-T08
A	D40-D50	S030L08S	WT-T08

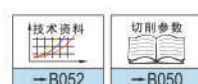



P110系列大进给铣刀 P110 Series high feed milling cutters

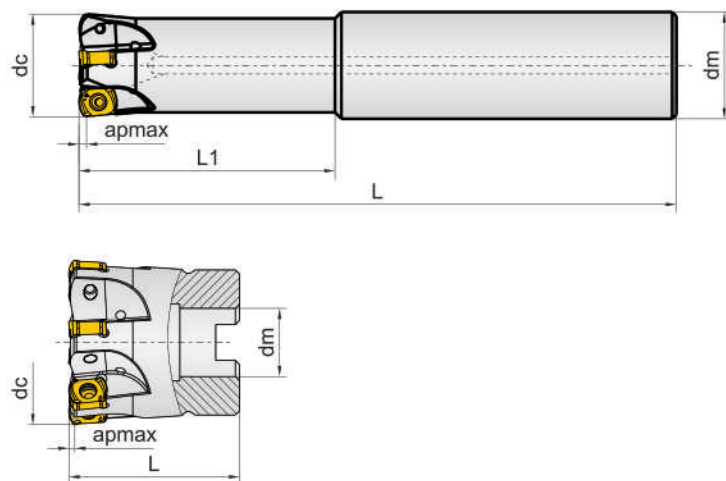

B

型号 Type	库存状态 Stock	尺寸 (mm) Dimension						齿数 Teeth Z	内冷状态 Cooling	重量 kg
		dc	dm	apmax	L1	L				
P110-16Z02LN06-C16	●	16	16	0.8	30	100		2	+	0.06
P110-20Z03LN06-C20	●	20	20	0.8	50	130		3	+	0.09
P110-25Z04LN06-C25	●	25	25	0.8	60	140		4	+	0.14
P110-32Z05LN06-C32	●	32	32	0.8	60	150		5	+	0.30
P110-40Z06LN06-A16	●	40	16	0.8	-	40		6	+	0.80
P110-50Z07LN06-A22	●	50	22	0.8	-	50		7	+	1.10

● 常备库存 regular stock ○ 按订单生产 order for manufacturing

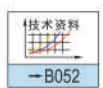

P110系列大进给铣刀 P110 Series high feed milling insert

编程圆角R2

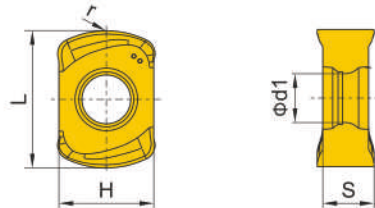

B

型号 Type	基本尺寸 (mm) Dimension					P		M		K		S		N		
	L	H	S	d1	r	PP2125	PX6140	PP2125	PX6140	PX5110	PP2125	PX6140	PP4115	PX6140	PH3110	PH3120
LNMU0603R-M	9	6.22	3.37	3.2	6	★	☆	★	☆	☆	★					
LNMU0603R-L	9	6.22	3.37	3.2	6	★	☆	★	☆	☆	★					

★ 为第一推荐牌号 Recommended Grade
☆ 为第二推荐牌号 Optional Grade

配件/SPARE PARTS

安装形式 Type of clamping	刀具直径(mm) Diameter (mm)	螺钉 Screw	扳手 Wrench
C	D16-D32	S025L06	WT07
A	D40-D50	S025L06	WT07

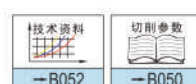



P190系列方肩铣刀
P190 series shoulder milling cutter

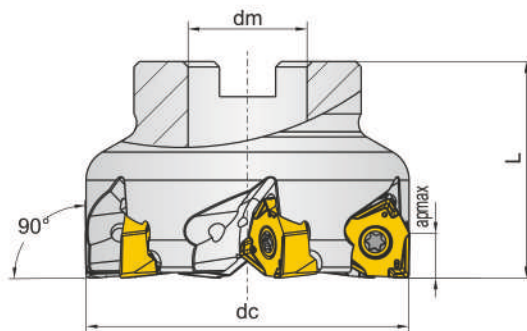
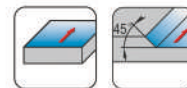

B

型号 Type	库存状态 Stock	尺寸 (mm) Dimension						齿数 Teeth Z	内冷状态 Cooling	重量 kg
		dc	dm	apmax	L					
P190-40Z03ZN08-A16	○	40	16	5	40			3	+	0.40
P190-50Z05ZN08-A22	●	50	22	5	40			5	+	0.50
P190-63Z06ZN08-A22	●	63	22	5	40			6	+	0.60
P190-80Z07ZN08-A27	●	80	27	5	50			7	+	1.70
P190-100Z08ZN08-A32	○	100	32	5	50			8	+	1.80
P190-125Z10ZN08-A40	○	125	40	5	63			10	+	3.70

● 常备库存 regular stock ○ 按订单生产 order for manufacturing



P190系列方肩铣刀刀片
P190 series shoulder milling insert

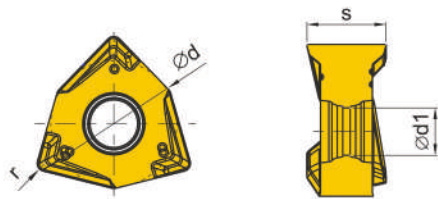
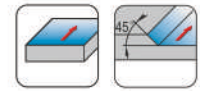

B

加工状态 Working Condition:	● 稳定切削 Steady Cutting	◐ 一般切削 General Cutting	○ 不稳定切削 Unsteady Cutting																	
	●	◐	○																	

型号 Type	基本尺寸 (mm) Dimension				P		M		K		S		N		
	d	s	d1	r	PP2125	PX6140	PP2125	PX6140	PX5110	PP2125	PX6140	PP4115	PX6140	PH3110	PH3120
ZNGX080608FR-BM	12.5	7.85	4.7	0.8	★	☆	★	☆	☆	★	☆			☆	★

★ 为第一推荐牌号 Recommended Grade
☆ 为第二推荐牌号 Optional Grade

配件/SPARE PARTS

安装形式 Type of clamping	刀具直径(mm) Diameter (mm)	螺钉 Screw	扳手 Wrench
A	D40-D125	S040L10T	T15-T



P190系列方肩铣刀
P190 series shoulder milling cutter

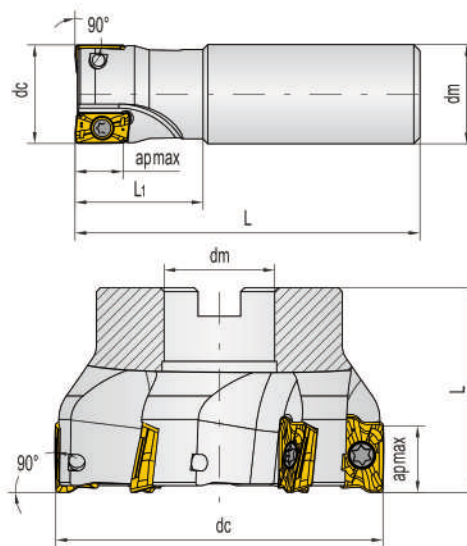
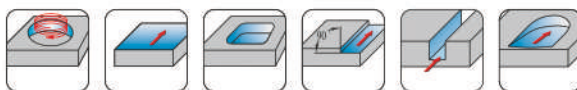

B

型号 Type	库存状态 Stock	尺寸 (mm) Dimension							齿数 Teeth Z	内冷状态 Cooling	重量 kg
		dc	dm	apmax	L	L1					
P190-10Z01AP11N-C10	○	10	10	9	100	25			1		0.05
P190-12Z01AP11N-C12	○	12	12	9	120	30			1		0.10
P190-16Z02AP11N-C16	○	16	16	9	120	40			2		0.17
P190-20Z02AP11N-C20	○	20	20	9	120	50			2		0.26
P190-25Z02AP17-C25	○	25	25	16	160	48			2		0.55
P190-30Z02AP17-C25	○	30	25	16	160	48			2		0.81
P190-32Z02AP17-C32	○	32	32	16	160	48			2		0.86
P190-35Z02AP17-C32	○	35	32	16	160	48			2		0.95
P190-35Z03AP17-C32	○	35	32	16	160	60			3		0.94
P190-40Z03AP17-C32	○	160	40	16	160	60			3		1.10
P190-50Z04AP17-A22	○	50	22	16	50				4		0.40
P190-63Z05AP17-A22	○	63	22	16	50				5		0.65
P190-80Z06AP17-A27	○	80	27	16	50				6		1.00
P190-100Z06AP17-A32	○	100	32	16	50				6		1.25
P190-125Z08AP17-A40	○	125	40	16	63				8		3.10
P190-160Z08AP17-B40	○	160	40	16	63				8		5.10

● 常备库存 regular stock ○ 按订单生产 order for manufacturing



P190系列方肩铣刀刀片
P190 series shoulder milling insert

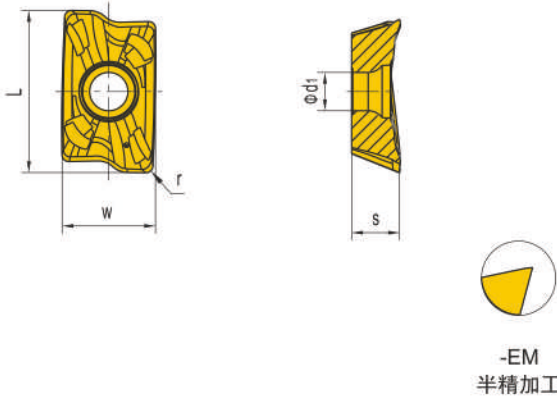

B

型号 Type	基本尺寸 (mm) Dimension					P		M		K		S		N		
	L	w	s	d1	r	PP2125	PX6140	PP2125	PX6140	PX5110	PP2125	PX6140	PP4115	PX6140	PH3110	PH3120
APMT1135PDER-EM	11.2	6.24	3.5	2.8	0.8	★	☆	★			★	☆			☆	★
APMT1604PDER-EM	17.4	9.32	5.28	4.4	0.8	★	☆	★			★	☆			☆	★
APMT170508R-EM	18.54	10.63	5.56	4.4	0.8	★	☆	★			★	☆			☆	★
APMT170516R-EM	18.54	10.63	5.56	4.4	1.6	★	☆	★			★	☆			☆	★
APGT170508FR-AL	17.5	10.8	5.3	4.4	0.8										☆	★

★ 为第一推荐牌号 Recommended Grade
☆ 为第二推荐牌号 Optional Grade

配件/SPARE PARTS

安装形式 Type of clamping	刀具直径(mm) Diameter (mm)	螺钉 Screw	扳手 Wrench
C	D10-D20	S025L06T	T07
C	D25-D40	S040L09T	T15-F
A	D50-D125	S040L09T	T15-T
B	D160	S040L09T	T15-T

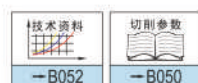

P190系列方肩铣刀
P190 series shoulder milling cutter

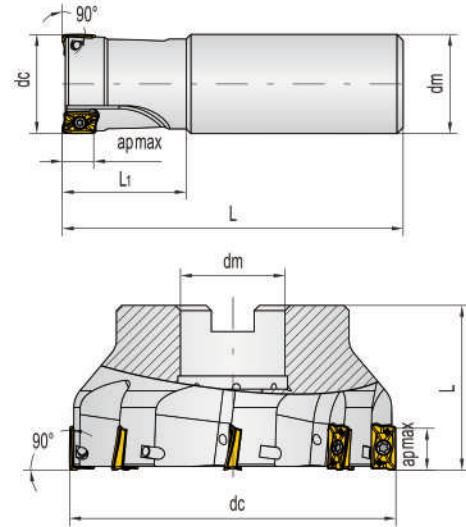
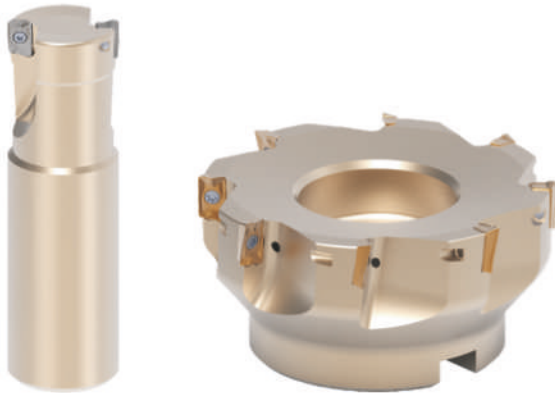
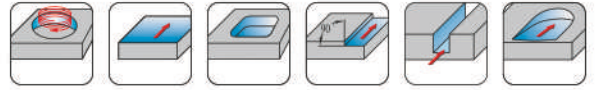

B

型号 Type	库存状态 Stock	尺寸 (mm) Dimension							齿数 Teeth Z	内冷状态 Cooling	重量 kg
		dc	dm	apmax	L	L1					
P190-16Z02AOMX11-C16	●	16	16	10	100	30			2		0.20
P190-20Z02AOMX11-C20	●	20	20	10	100	30			2		0.30
P190-25Z02AOMX11-C25	●	25	25	10	100	30			2		0.45
P190-30Z03AOMX11-C32	●	30	25	10	120	30			3		0.50
P190-32Z03AOMX11-C32	●	32	32	10	120	30			3		0.70
P190-40Z04AOMX11-C32	●	40	32	10	120	30			4		0.80
P190-40Z02AOMX11-A16	●	40	16	10	40				2		0.50
P190-50Z02AOMX11-A22	●	50	22	10	40				2		0.60
P190-63Z02AOMX11-A22	●	63	22	10	40				2		0.60
P190-80Z03AOMX11-A27	○	80	27	10	50				3		0.70
P190-25Z02AOMX17-C25	○	25	25	15.7	120	30			2		0.50
P190-30Z03AOMX17-C32	○	20	20	15.7	120	30			3		0.60
P190-32Z03AOMX17-C32	○	25	25	15.7	160	30			3		1.00
P190-40Z04AOMX17-C32	○	30	25	15.7	160	30			4		1.10
P190-50Z04AOMX17-A22	○	50	22	15.7	40				4		0.60
P190-63Z05AOMX17-A22	●	63	22	15.7	40				5		0.70
P190-80Z06AOMX17-A27	○	80	27	15.7	50				6		1.00
P190-100Z07AOMX17-A32	○	100	32	15.7	50				7		1.80
P190-125Z08AOMX17-A40	○	125	40	15.7	63				8		2.70
P190-160Z12AOMX17-B40	○	160	40	15.7	63				12		3.90

● 常备库存 regular stock ○ 按订单生产 order for manufacturing



P190系列方肩铣刀刀片 P190 series shoulder milling insert

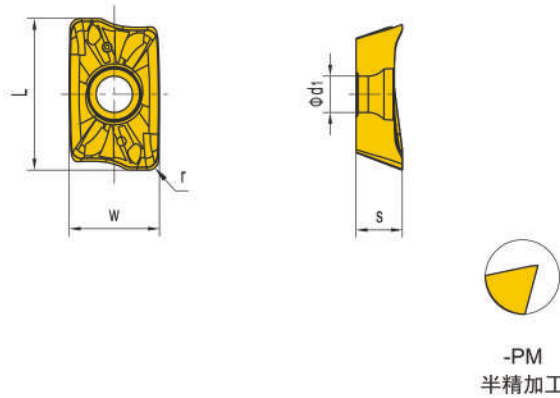

B

加工状态 Working Condition:	● 稳定切削 Steady Cutting	◐ 一般切削 General Cutting	○ 不稳定切削 Unsteady Cutting	●	◐	○	●	◐	○	●	◐	○	●	◐	○
				●	◐	○	●	◐	○	●	◐	○	●	◐	○

型号 Type	基本尺寸 (mm) Dimension					P		M		K		S		N		
	L	w	s	d1	r	PP2125	PX6140	PP2125	PX6140	PX5110	PP2125	PX6140	PP4115	PX6140	PH3110	PH3120
AOMX11T308-PM	11.72	6.9	3.58	2.8	0.8	★	☆	★			★	☆				
AOMX11T308-PL	11.72	6.9	3.58	2.8	0.8	★	☆	★			★	☆	☆			
AOGX11T320-PM	11.68	6.95	3.6	2.8	2.0	★	☆	★			★	☆				
AOMX11T331-PM	11.86	6.9	3.58	3.6	3.1	★	☆	★			★	☆				
AOMX170408-PL	17.82	9.6	4.76	4.12	0.8	★	☆	★			★	☆	☆			
AOMX170408-PM	17.82	9.6	4.76	4.12	0.8	★	☆	★			★	☆				

★ 为第一推荐牌号 Recommended Grade
☆ 为第二推荐牌号 Optional Grade

配件/SPARE PARTS

安装形式 Type of clamping	刀具直径(mm) Diameter (mm)	螺钉 Screw	扳手 Wrench
C	D16-D40	S025L06S	WT07-F
A	D40-D80	S025L06S	WT07-F
B	D160	S025L06S	WT07-F

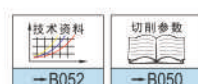



螺旋刃立铣刀
Helical milling cutter

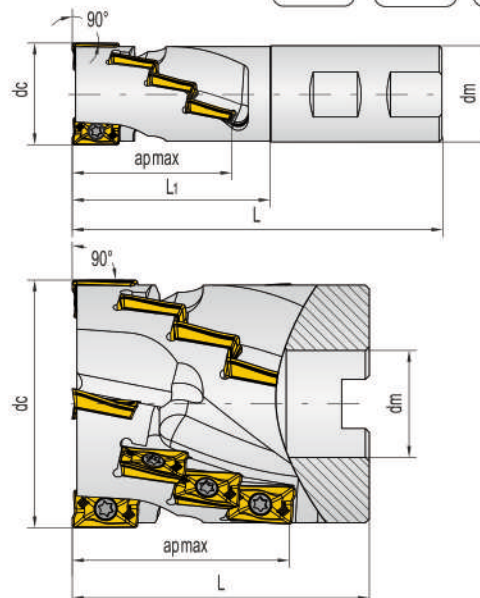
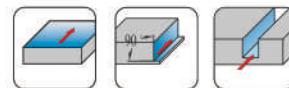

B

型号 Type	库存状态 Stock	尺寸 (mm) Dimension					齿数 Teeth Z	总刀片数 QTY of inserts N	内冷状态 Cooling	重量 kg
		dc	dm	apmax	L	L1				
P190-40Z02AOMX17-E40	○	40	40	60	175	95	2	8		1.25
P190-50Z03AOMX17-E40	○	50	40	60	175	95	3	12		2.60
P190-50Z03AOMX17-A22	○	50	22	60	90		3	12		1.20
P190-63Z04AOMX17-A27	○	63	27	60	90		4	16		1.75
P190-80Z04AOMX17-A32	○	80	32	60	90		4	16		3.60

● 常备库存 regular stock ○ 按订单生产 order for manufacturing



螺旋刃立铣刀刀片 Helical milling inserts

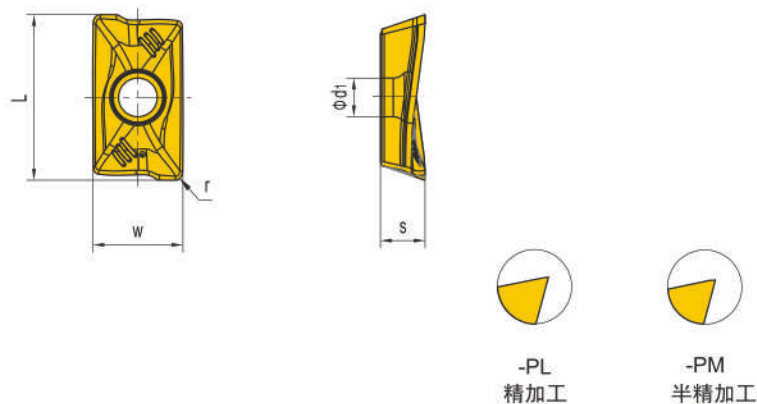

B

加工状态 Working Condition:

- 稳定切削 Steady Cutting
- ◐ 一般切削 General Cutting
- 不稳定切削 Unsteady Cutting

●		●		●		●														
◐	◐	◐	◐	◐	◐															
	○		○		○															

型号 Type	基本尺寸 (mm) Dimension					P		M		K		S		N						
	L	w	s	d1	r	PP2125	PX6140	PP2125	PX6140	PX5110	PP2125	PX6140	PP4115	PX6140	PH3110	PH3120				
AOMX170408-PL	17.82	9.6	4.76	4.12	0.8	★	☆	★		☆	★	☆								
AOMX170408-PM	17.82	9.6	4.76	4.12	0.8	★	☆	★		☆	★	☆								

★ 为第一推荐牌号 Recommended Grade
☆ 为第二推荐牌号 Optional Grade

配件/SPARE PARTS

安装形式 Type of clamping	刀具直径(mm) Diameter (mm)	螺钉 Screw	扳手 Wrench
E	D40-D50	S035L08T	T20-T
A	D50-D80	S035L08T	T20-T

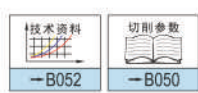

螺旋刃立铣刀
Helical milling cutter

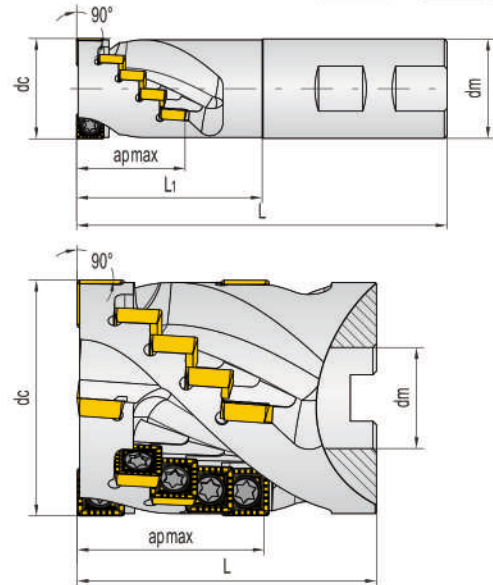
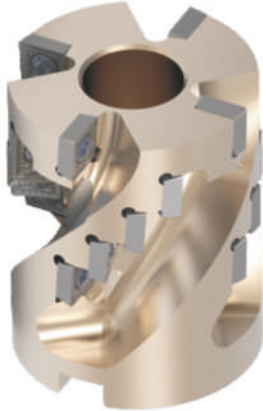

B

型号 Type	库存状态 Stock	尺寸 (mm) Dimension					齿数 Teeth Z	总刀片数 QTY of inserts N	内冷状态 Cooling	重量 kg
		dc	dm	apmax	L	L1				
P190-40Z02SP12-E40	○	40	40	50	175	95	2	10		1.20
P190-50Z03SP12-E40	○	50	40	50	175	95	3	15		2.50
P190-50Z03SP12-A22	○	50	22	50	80		3	15		1.20
P190-63Z04SP12-A27	○	63	27	50	80		4	20		1.80
P190-80Z04SP12-A32	○	80	32	50	80		4	20		2.60

● 常备库存 regular stock ○ 按订单生产 order for manufacturing



螺旋刃立铣刀刀片 Helical milling inserts

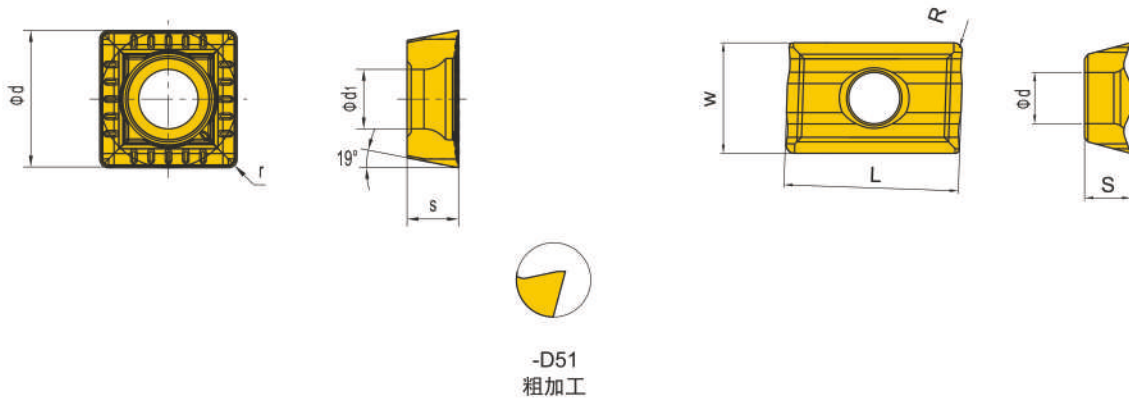

B

加工状态 Working Condition:	● 稳定切削 Steady Cutting	◐ 一般切削 General Cutting	○ 不稳定切削 Unsteady Cutting																	

型号 Type	基本尺寸 (mm) Dimension						P		M		K		S		N				
	d	s	d1	r	L	W	PP2125	PX6140	PP2125	PX6140	PX5110	PP2125	PX6140	PP4115	PX6140	PH3110	PH3120		
SPMT120408-D51	12.7	4.76	5.5	0.8			★	☆	★	☆		★	☆						
LPMT15T308R-D51		3.97	5.5	0.8	15.88	12.7	★	☆	★	☆		★	☆						
LDHT15T308FR-LHC		3.97	4.4	0.8	15	9.5										★	☆		

★ 为第一推荐牌号 Recommended Grade
☆ 为第二推荐牌号 Optional Grade

配件/SPARE PARTS

安装形式 Type of clamping	刀具直径(mm) Diameter (mm)	螺钉 Screw	扳手 Wrench
E	D40-D50	S050L12T	T20-T
A	D50-D80	S050L12T	T20-T

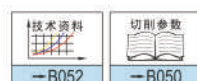



P100系列仿形铣刀
P100 series profile milling cutter

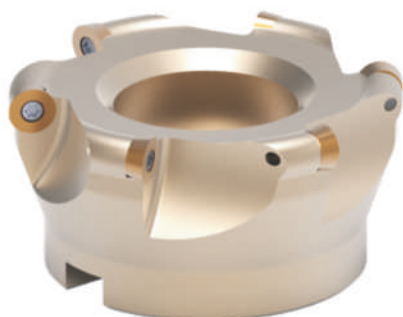
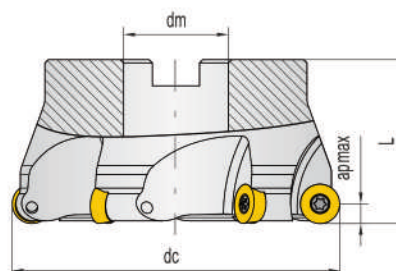
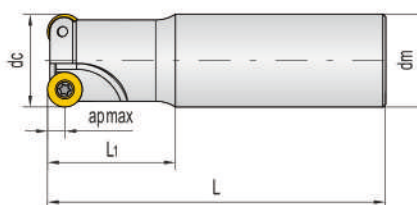

B

型号 Type	库存状态 Stock	尺寸 (mm) Dimension							齿数 Teeth Z	内冷状态 Cooling	重量 kg
		dc	dm	apmax	L	L1					
P100-25Z02RP10-C20	○	25	20	5	100	35			2	+	0.20
P100-32Z02RP10-C25	○	32	25	5	120	40			2	+	0.50
P100-40Z03RP10-C32	○	40	32	5	120	40			3	+	0.70
P100-50Z03RP10-C32	○	50	32	5	120	40			3	+	0.80
P100-40Z05RP10-A16	○	40	16	5	40				5	+	0.44
P100-50Z05RP10-A22	○	50	22	5	40				5	+	0.87
P100-63Z06RP10-A22	○	63	22	5	40				6	+	0.60
P100-80Z07RP10-A27	○	80	27	5	50				6	+	1.40
P100-32Z02RP12-C25	○	32	25	6	135	40			2	+	0.90
P100-40Z03RP12-C32	○	40	32	6	150	40			3	+	1.00
P100-50Z04RP12-C32	○	50	32	6	150	40			4	+	1.10
P100-50Z04RP12-A22	○	50	22	6	45				4	+	0.40
P100-63Z04RP12-A22	○	63	22	6	45				4	+	0.60
P100-80Z05RP12-A27	○	80	27	6	50				5	+	1.10

● 常备库存 regular stock ○ 按订单生产 order for manufacturing



P100系列仿形铣刀刀片

P100 series profile milling insert

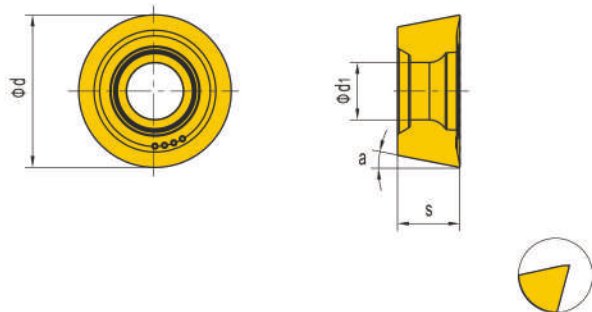

-MV
精/半精加工

B

加工状态 Working Condition:	● 稳定切削 Steady Cutting		● 一般切削 General Cutting		○ 不稳定切削 Unsteady Cutting							
	●	○	●	○	●	○	●	○	●	○	●	○
	○	○	○	○	○	○	○	○	○	○	○	○

型号 Type	基本尺寸 (mm) Dimension				P		M		K		S		N		
	d	s	d1	α	PP2125	PX6140	PP2125	PX6140	PX5110	PP2125	PX6140	PP4115	PX6140	PH3110	PH3120
RPGT0803MOE-MV	8	3.18	3.4	11°	☆		☆			☆		★			
RPGT10T3MOE-MV	10	3.97	4.4	11°	☆		☆			☆		★			
RPMT1204MOE-MV	12	4.76	4.4	11°	☆		☆			☆		★			
RCMT1606MOS-MP	16	6.35	5.5	7°	☆		☆			☆		★			
RCMT2006MOE-HM	20	6.35	6.5	7°	☆		☆			☆		★			

★ 为第一推荐牌号 Recommended Grade
☆ 为第二推荐牌号 Optional Grade

配件/SPARE PARTS

安装形式 Type of clamping	刀具直径(mm) Diameter (mm)	螺钉 Screw	扳手 Wrench
C	D12-D32	S030L08T	T10-F
A	D40-D125	S030L08T	T10-F

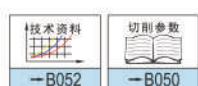



P116系列仿形铣刀
P116 series profile milling cutter

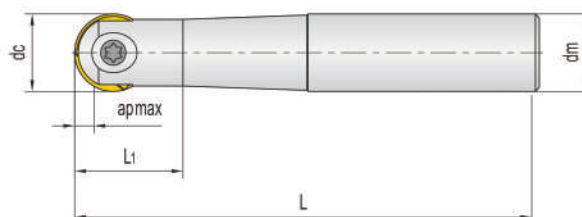

B

型号 Type	库存状态 Stock	尺寸 (mm) Dimension							齿数 Teeth Z	内冷状态 Cooling	重量 kg
		dc	dm	apmax	L	L1					
P116F-08Z01RO08-C12	○	8	12	1.2	110	42			1		0.20
P116F-10Z01RO10-C12	○	10	12	1.5	110	52			1		0.17
P116F-12Z01RO12-C12	○	12	12	1.8	110	52			1		0.20
P116F-16Z01RO16-C16	○	16	16	2.4	120	60			1		0.30
P116F-20Z01RO20-C20	○	20	20	3.0	120	60			1		0.28
P116F-25Z01RO25-C25	○	25	25	3.8	120	60			1		0.40
P116F-32Z01RO32-C32	○	32	32	4.8	160	60			1		1.05

● 常备库存 regular stock ○ 按订单生产 order for manufacturing

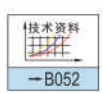

P116系列仿形铣刀刀片

P116 series profile milling insert

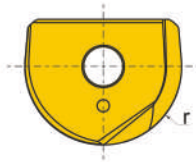

-EL
精加工

B

加工状态 Working Condition:

● 稳定切削 Steady Cutting	● 一般切削 General Cutting	○ 不稳定切削 Unsteady Cutting	●	●	●	●	●	●	●	●	●	●	●	●	●	●	●	●
			○	○	○	○	○	○	○	○	○	○	○	○	○	○	○	○

型号 Type	基本尺寸 (mm) Dimension				P		M		K		S		N		
	d	r	s		PP2125	PX6140	PP2125	PX6140	PX5110	PP2125	PX6140	PP4115	PX6140	PH3110	PH3120
	ROHT0824-EL	8	4	2.40		☆		☆			☆		☆		☆
ROHT1026-EL	10	5	2.60		☆		☆			☆		☆		☆	
ROHT1230-EL	12	6	3.00		☆		☆			☆		☆		☆	
ROHT1640-EL	16	8	4.00		☆		☆			☆		☆		☆	
ROHT2050-EL	20	10	5.00		☆		☆			☆		☆		☆	
ROHT2560-EL	25	12.5	6.00		☆		☆			☆		☆		☆	
ROHT3070-EL	30	15	7.00		☆		☆			☆		☆		☆	
ROHT3270-EL	32	16	7.00		☆		☆			☆		☆		☆	

★ 为第一推荐牌号 Recommended Grade
 ☆ 为第二推荐牌号 Optional Grade
 无库存 No stock

配件/SPARE PARTS

安装形式 Type of clamping	刀具直径(mm) Diameter (mm)	螺钉 Screw	扳手 Wrench
C	D8-D10	S035L08-A	WT10
C	D12	S040L10-A	WT15
C	D16-D20	S050L16-A	WT20
C	D25	S060L20-A	WT25
C	D30	S080L25-A	WT30
C	D32	S080L25-A	WT30

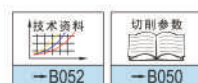



P990系列铝合金面铣刀
P990 series aluminum face milling cutter

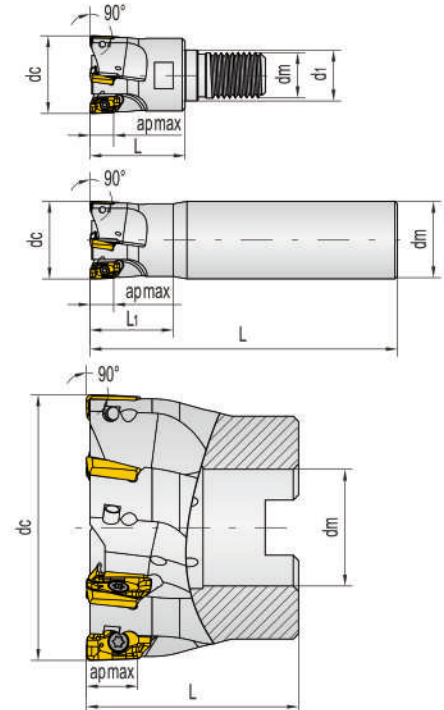
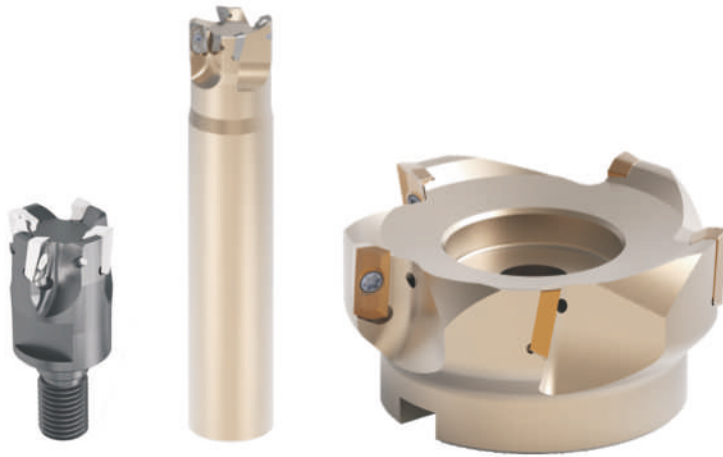
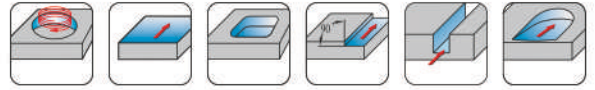

B

型号 Type	库存状态 Stock	尺寸 (mm) Dimension							齿数 Teeth Z	内冷状态 Cooling	重量 kg
		dc	dm	apmax	L	d1	L1				
P990-16Z02XD11-M08	●	16	M8	10	25	8.5			2	+	0.1
P990-20Z03XD11-M10	●	20	M10	10	30	10.5			3	+	0.15
P990-25Z04XD11-M12	●	25	M12	10	35	12.5			4	+	0.23
P990-32Z05XD11-M16	●	32	M16	10	43	17			5	+	0.35
P990-16Z02XD11-C16	●	16	16	10	165		32		2	+	0.2
P990-20Z03XD11-C20	●	20	20	10	165		40		3	+	0.26
P990-25Z04XD11-C25	●	25	25	10	225		50		4	+	0.5
P990-32Z05XD11-C32	●	32	32	10	225		50		5	+	0.8
P990-40Z05XD11-A16	○	40	16	10	40				5	+	0.2
P990-50Z06XD11-A22	○	50	22	10	40				6	+	0.35

● 常备库存 regular stock ○ 按订单生产 order for manufacturing



P990系列铝合金面铣刀刀片
P990 series aluminum face milling insert

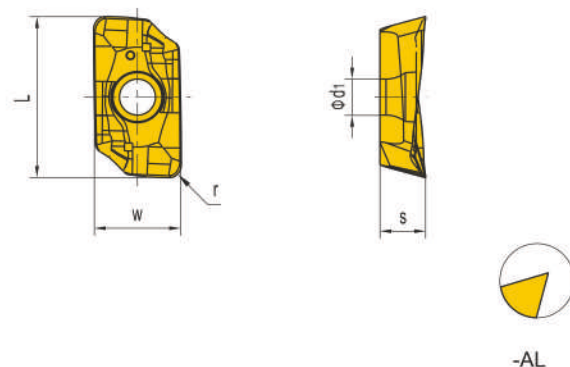

B

加工状态 Working Condition:	● 稳定切削 Steady Cutting	◐ 一般切削 General Cutting	○ 不稳定切削 Unsteady Cutting																	●	
																					◐
																					○

型号 Type	基本尺寸 (mm) Dimension					P		M		K		S		N		
	L	w	s	d1	r	PP2125	PX6140	PP2125	PX6140	PX5110	PP2125	PX6140	PP4115	PX6140	PH3110	PH3120
XDGT113504PDFR-AL	12.58	6.6	3.5	2.8	0.4										☆	★
XDGT113508PDFR-AL	12.58	6.6	3.5	2.8	0.8										☆	★
XDGT113510PDFR-AL	12.58	6.6	3.5	2.8	1.0										☆	★
XDGT113530PDFR-AL	12.58	6.6	3.5	2.8	3.0										☆	★

★ 为第一推荐牌号 Recommended Grade
☆ 为第二推荐牌号 Optional Grade

配件/SPARE PARTS

安装形式 Type of clamping	刀具直径(mm) Diameter (mm)	螺钉 Screw	扳手 Wrench
M	D16-D32	S025L06S	WT07-F
C	D16-D32	S025L06S	WT07-F
A	D40-D50	S025L06S	WT07-F

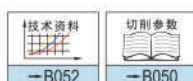

P990系列铝合金面铣刀 P990 series aluminum face milling cutter

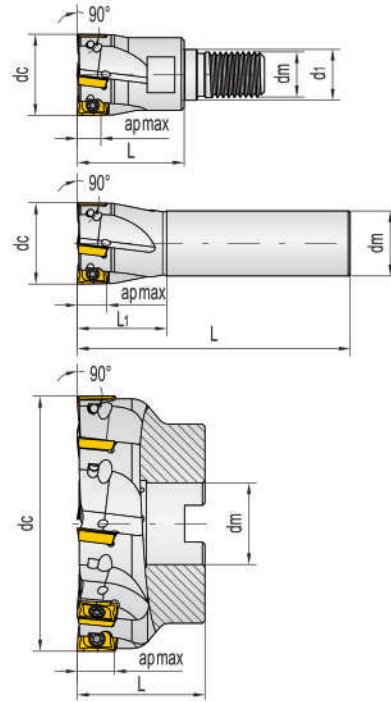
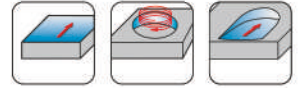

B

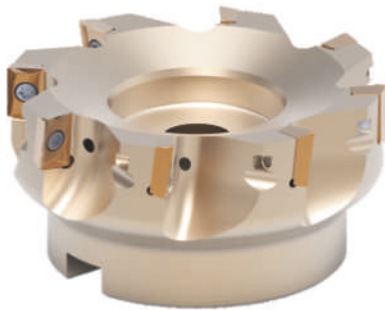

型号 Type	库存状态 Stock	尺寸 (mm) Dimension								齿数 Teeth Z	内冷状态 Cooling	重量 kg
		dc	dm	apmax	L	d1	L1					
P990-25Z02XD15-M12	○	25	M12	13	45	12.5				2	+	0.23
P990-32Z02XD15-M16	○	32	M16	13	52	17				2	+	0.35
P990-40Z03XD15-M16	○	40	M16	13	52	17				3	+	0.55
P990-25Z02XD15-C25	○	25	25	13	100		40			2	+	0.5
P990-32Z02XD15-C32	○	32	32	13	110		40			2	+	0.8
P990-40Z03XD15-C32	○	40	32	13	110		40			3	+	1.15
P990-40Z04XD15-A16	○	40	16	13	40					4	+	0.3
P990-50Z05XD15-A22	●	50	22	13	40					5	+	0.52
P990-63Z06XD15-A22	●	63	22	13	40					6	+	0.6
P990-80Z07XD15-A27	○	80	27	13	50					7	+	1.1
P990-100Z08XD15-A32	○	100	32	13	50					8	+	1.7
P990-125Z10XD15-A40	○	125	40	13	63					10	+	2.6

● 常备库存 regular stock ○ 按订单生产 order for manufacturing



P990系列铝合金面铣刀刀片
P990 series aluminum face milling insert

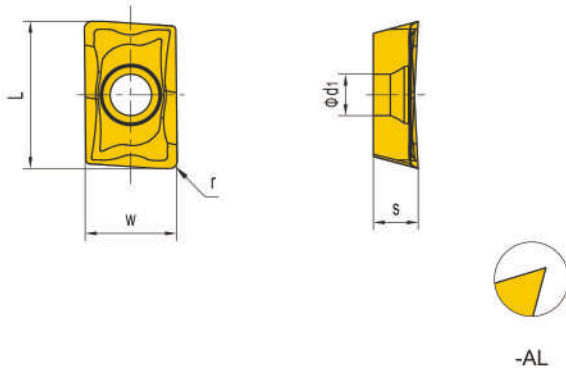

B

加工状态 Working Condition:																			●
● 稳定切削 Steady Cutting										○ 不稳定切削 Unsteady Cutting									
● 一般切削 General Cutting																			

型号 Type	基本尺寸 (mm) Dimension					P		M		K		S		N		
	L	w	s	d1	r	PP2125	PX6140	PP2125	PX6140	PX5110	PP2125	PX6140	PP4115	PX6140	PH3110	PH3120
XDGT150404FR-AL	15.58	9.7	4.76	4.4	0.4										☆	★
XDGT150408FR-AL	15.58	9.7	4.76	4.4	0.8										☆	★
XDGT150412FR-AL	15.58	9.7	4.76	4.4	1.2										☆	★

★ 为第一推荐牌号 Recommended Grade
☆ 为第二推荐牌号 Optional Grade

配件/SPARE PARTS

安装形式 Type of clamping	刀具直径(mm) Diameter (mm)	螺钉 Screw	扳手 Wrench
M	D25-D40	S035L08T	T15-F
A	D40-D125	S035L08T	T15-F
C	D25-D40	S035L08T	T15-F

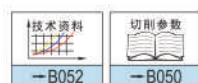

P990系列铝合金面铣刀 P990 series aluminum face milling cutter

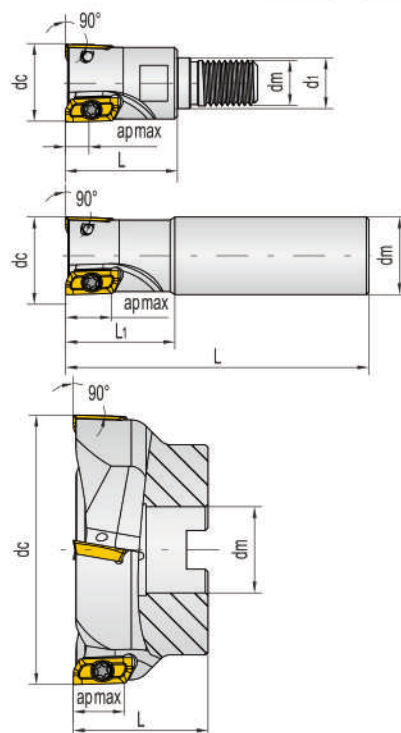
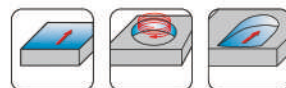

B



型号 Type	库存状态 Stock	尺寸 (mm) Dimension							齿数 Teeth Z	内冷状态 Cooling	重量 kg
		dc	dm	apmax	L	d1	L1				
P990-25Z02XD19-M12	○	25	M12	18	45	12.5			2	+	0.25
P990-32Z03XD19-M16	○	32	M16	18	52	17			3	+	0.32
P990-40Z03XD19-M16	○	40	M16	18	52	17			3	+	0.5
P990-25Z02XD19-C25	●	25	25	18	125		45		2	+	0.5
P990-32Z03XD19-C32	○	32	32	18	125		45		3	+	0.8
P990-40Z03XD19-A16	○	40	16	18	50				3	+	0.3
P990-50Z04XD19-A22	●	50	22	18	50				4	+	0.52
P990-63Z05XD19-A22	●	63	22	18	50				5	+	1.1
P990-80Z05XD19-A27	○	80	27	18	50				5	+	1.9
P990-100Z05XD19-A32	○	100	32	18	50				5	+	3.8
P990-125Z06XD19-A40	○	125	40	18	63				6	+	4.4

● 常备库存 regular stock ○ 按订单生产 order for manufacturing



P990系列铝合金面铣刀刀片
P990 series aluminum face milling insert

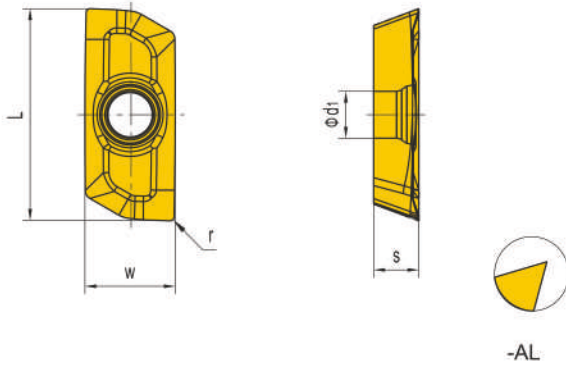

B

加工状态 Working Condition:

● 稳定切削 Steady Cutting ◐ 一般切削 General Cutting ○ 不稳定切削 Unsteady Cutting

																		●
																		◐
																		○

型号 Type	基本尺寸 (mm) Dimension					P		M		K		S		N		
	L	w	s	d1	r	PP2125	PX6140	PP2125	PX6140	PX5110	PP2125	PX6140	PP4115	PX6140	PH3110	PH3120
XDGT190404FR-AL	22.1	9.525	4.76	4.7	0.4										☆	★
XDGT190408FR-AL	22.1	9.525	4.76	4.7	0.8										☆	★
XDGT190412FR-AL	22.1	9.525	4.76	4.7	1.2										☆	★
XDGT190420FR-AL	22.1	9.525	4.76	4.7	2.0										☆	★
XDGT190424FR-AL	22.1	9.525	4.76	4.7	2.4										☆	★
XDGT190432FR-AL	22.1	9.525	4.76	4.7	3.2										☆	★

★ 为第一推荐牌号 Recommended Grade
☆ 为第二推荐牌号 Optional Grade

配件/SPARE PARTS

安装形式 Type of clamping	刀具直径(mm) Diameter (mm)	螺钉 Screw	扳手 Wrench
M	D25-D40	S040L09T	T15-F
A	D40-D125	S040L09T	T15-F
C	D25-D32	S040L09T	T15-F



P990系列铝合金面铣刀 P990 Series face milling cutter for Aluminum



Kr:90°

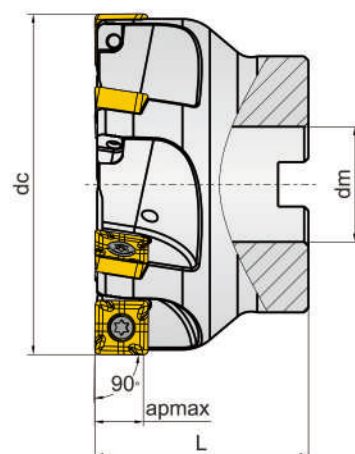

B

型号	库存状态	基本尺寸(mm)						齿数 Teeth Z	内冷状态 Cooling	重量 kg
		dc	dm	aymax	L					
P990-63Z05SD12-A22	●	63	22	10	50			5	+	0.70
P990-80Z06SD12-A27	●	80	27	10	50			6	+	1.20
P990-100Z07SD12-A32	●	63	32	10	50			7	+	1.90
P990-125Z08SD12-A40	○	80	40	10	63			8	+	3.40

● 常备库存 regular stock ○ 按订单生产 order for manufacturing

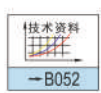

P990系列铝合金面铣刀刀片
P990 series aluminum face milling insert

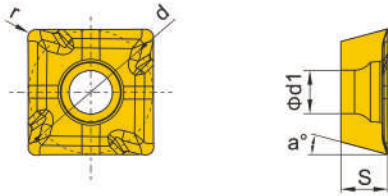

B

型号 Type	基本尺寸 (mm) Dimension					P		M		K		S		N		
	d	s	d1	r	a	PP2125	PX6140	PP2125	PX6140	PX5110	PP2125	PX6140	PP4115	PX6140	PH3110	PH3120
SDGT120404PDFR-LHC	12.7	4.76	4.4	0.4	15										☆	★
SDGT120408PDFR-LHC	12.7	4.76	4.4	0.8	15										☆	★
SDGT120412PDFR-LHC	12.7	4.76	4.4	1.2	15										☆	★

★ 为第一推荐牌号 Recommended Grade
☆ 为第二推荐牌号 Optional Grade

配件/SPARE PARTS

安装形式 Type of clamping	刀具直径(mm) Diameter (mm)	螺钉 Screw	扳手 Wrench
A	D63-D125	S040L10T	T15-T



P990系列铝合金面铣刀
P990 series face milling cutter for Aluminum



Kr:90°

B

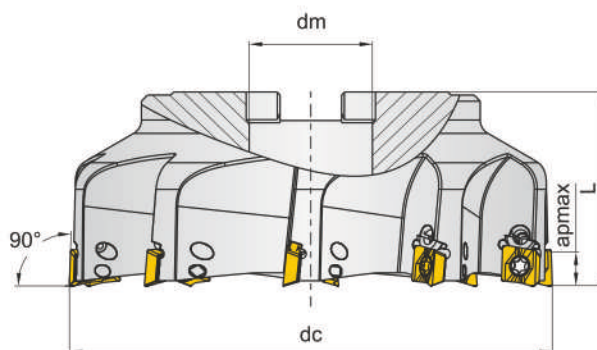
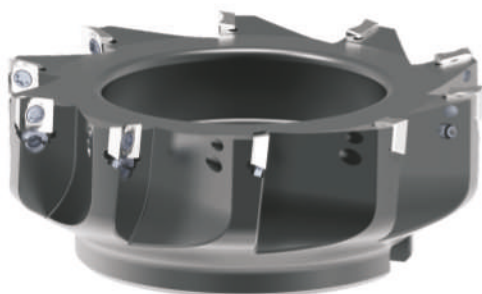

型号	库存状态	基本尺寸(mm)						齿数 Teeth Z	内冷状态 Cooling	重量 kg
		dc	dm	apmax	L					
P990-50Z04AOGX1105-A22	○	50	22	11	40			4	+	0.80
P990-63Z05AOGX1105-A22	○	63	22	11	40			5	+	0.80
P990-80Z06AOGX1105-A27	○	80	27	11	50			6	+	0.90
P990-100Z06AOGX1105-A32	○	100	32	11	50			6	+	1.00
P990-125Z08AOGX1105-A40	○	125	40	11	63			8	+	1.90

● 常备库存 regular stock ○ 按订单生产 order for manufacturing



P990系列铝合金面铣刀刀片
P990 series aluminum face milling insert

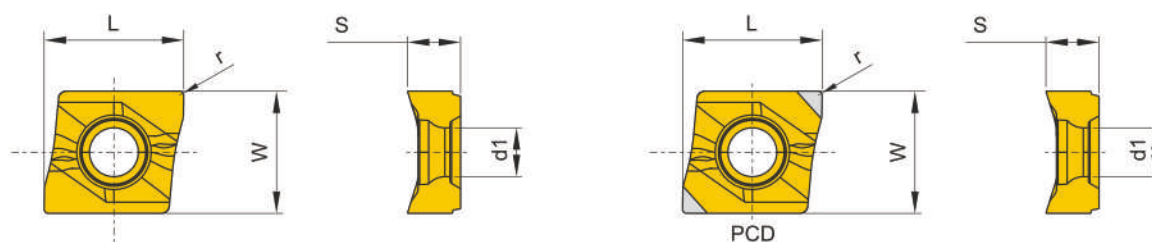

B

加工状态 Working Condition:

- 稳定切削 Steady Cutting
- ◐ 一般切削 General Cutting
- 不稳定切削 Unsteady Cutting

											●	
											◐	◐
											○	

型号 Type	基本尺寸 (mm) Dimension					P		M		K		N			
	L	W	S	d1	r	PP2125	PX6140	PP2125	PX6140	PX5110	PP2125	PX6140	PH3110	PH3120	PCD20
AOGX110504-AL	13.18	11.53	5.00	4.60	0.2-1.2								★	★	★
AOGX110504-KL	13.18	11.53	5.00	4.60	0.2-1.2								★	★	★

★ 为第一推荐牌号 Recommended Grade
☆ 为第二推荐牌号 Optional Grade

配件/SPARE PARTS

安装形式 Type of clamping	刀具直径(mm) Diameter (mm)	螺钉 Screw	扳手 Wrench
A	D50-D125	S040L10T	T15-T

